

# SOLIDWORKS Sustainability Guide

## Contents

- Sustainable Design Guide..... 4
- Chapter 1: Introduction and Terminology ..... 4
  - Why should you read this guide?..... 4
    - Personal interest ..... 4
    - Company intent..... 4
    - Industry regulations ..... 4
  - How Should You Use This Guide? ..... 5
- Chapter 2: Sustainability and Sustainable Business..... 5
  - Definitions of sustainability ..... 5
  - Scope of sustainability ..... 6
  - Sustainable Company..... 6
  - The Many Faces of Sustainable Design ..... 7
    - Design for Disassembly ..... 8
    - Design for the Environment..... 8
    - Product stewardship ..... 8
    - Cradle to Cradle ..... 8
    - Biomimicry ..... 9
    - Green chemistry..... 9
    - Green marketing ..... 9
- Chapter 3: Making Theory Matter - Initial Analysis Decisions ..... 10
  - Your influence is critical ..... 10
  - A sustainable design challenge ..... 11
  - Environmental Impact Assessment Tools & Techniques ..... 11
    - Sustainable design is relative ..... 11
    - What Am I Comparing?..... 12
    - What Am I Measuring? The Three Choices of Environmental Assessment..... 12
    - Choice 1: Environmental Indicators ..... 14
    - Choice 2: Scope ..... 18
    - Choice 3: Metrics ..... 24
- Chapter 4: Putting It All Together ..... 30

Intuition.....	30
Product Scorecards .....	31
Conceptual Life Cycle Thinking .....	31
Qualitative Life Cycle Assessment .....	32
Life Cycle-Based Design Assessment .....	35
Industry-specific.....	35
Industry-agnostic .....	35
Life Cycle Assessment .....	36
Goal & Scope Definition .....	37
Inventory Analysis.....	38
Impact Assessment .....	38
Interpretation.....	39
A Handy Table of Tools for the Three Choices.....	40
Chapter 5: So What? (Interpreting the Results) .....	40
Chapter 6: A Redesigned Cup, A Reconsidered Toy.....	42
Priscilla’s Challenge.....	42
Tom’s Turn .....	56
Chapter 7: The Sustainable Design Strategies .....	66
Level 1: Product Design - Parametric Optimization .....	66
Sourcing Locally.....	66
Alternate Material Selection.....	66
Lightweighting (also called source reduction). .....	67
Level 2: Product Development - Fundamentally Altering the Product.....	67
Level 3: Product Innovation - Changing the System .....	67
Chapter 8: Communicating the Results .....	67
To designers and engineers unfamiliar with sustainable design .....	68
To general management.....	68
To other parts of the supply chain.....	69
To sales & marketing.....	69
Chapter 9: Next Steps .....	70
Chapter 10: For More Information .....	71
Appendix A - Reference Materials .....	71
Sustainability & Sustainable Business.....	71

Sustainable Living.....	72
The Hannover Principles .....	72
Appendix B - A Deeper Look at the LCA Process.....	72
Goal & Scope Definition .....	73
Inventory Analysis.....	75
Impact Assessment .....	76
Interpretation.....	80
Appendix C - LCA Tools and Methods .....	81
Commonly used LCA Tools.....	81
Impact Assessment Methodologies .....	82

## Sustainable Design Guide

The ideas of sustainability and sustainable design are a growing part of today's product design conversations. But exactly what is sustainable design, and how do you create a greener product? We'll answer these questions through this Guide to Sustainable Design with interactive content and detailed examples.

### Chapter 1: Introduction and Terminology

The idea of "Sustainable Design" is cropping up more and more in today's product design conversations. But what is sustainable design, and how do I do it? We hope to answer this question throughout this Guide.

#### Why should you read this guide?

There are probably as many reasons to read this guide as there are people reading it. That said, design engineers will want to incorporate sustainability principles into their work for at least one of four general reasons.

##### Personal interest

Many people are drawn to sustainable design because they want to use their talents and expertise to make the world a better place. As naïve as that sentiment might seem, it is a powerful driver behind a great deal of innovation and creative engineering. And, given the state of the world today, we could use all the help we can get.

##### Company intent

Many readers may be here not because of their own interest, but because sustainable design is part of a company initiative. Whether driven by stockholders, customers, or senior leadership, "sustainability" is increasingly on corporate agendas. While social and environmental responsibility is often at the root of such efforts, many companies are also finding that sustainable design is just "good business." Through it, companies find new ways to decrease material and energy costs, and increase revenue through resulting new product innovations.

##### Industry regulations

In many markets, regulations restrict the use of certain materials in products manufactured and sold there. For instance, in the European Union the Restriction of Hazardous Substances (RoHS) directive places strict guidelines on the use of specific materials in the manufacture of various electronics. Because this directive applies to products imported to, as well as made in, the EU, it impacts manufacturers worldwide. While adhering to sustainable design principles doesn't necessarily assure compliance with such directives, these practices do support increased attention to exactly the issues that such regulations are intended to address, such as the toxicity of certain substances.

Whether you are learning about sustainable design and engineering because you want to be, or because you need to be, this guide will help you develop a better understanding of the topic, along with the tools and techniques that will enable you to design more environmentally responsible products.<sup>1</sup>

### How Should You Use This Guide?

First, feel free to jump around. This guide was made to be consumed in parts, and in no particular order. We'll build some terminology early on, so if you find concepts that you're unfamiliar with, navigate to the appropriate section to learn more. Going through the entire Guide—and playing with some of the examples—should take about 5-7 hours, so it's a good idea to pace yourself (or skip to the good parts).

Second, we don't require that you have a copy of SOLIDWORKS Sustainability, or even SOLIDWORKS, handy—we've designed this Guide to be interesting and informative (we hope!) without having access to our design software. However, we've also included examples that you can download into your copy of SOLIDWORKS to make the theory come alive.

## Chapter 2: Sustainability and Sustainable Business

This section describes what is meant by “sustainability” and what you need to know about this concept. It starts out broadly, outlining why sustainability is important to the world, then what it means in the context of business, and finally why it is important in your role as a designer, engineer, product specialist, or other type of product design professional.

### Definitions of sustainability

Sustainability can be quite a malleable term. While most people understand its intention intuitively, it's difficult to actually pin down since it can cover so many domains. The World Commission on Environment and Development, known more popularly as the Brundtland Commission, created one of the best-known and often used definitions:

Sustainable development is development that meets the needs of the present without compromising the ability of future generations to meet their own needs.<sup>2</sup>

The Natural Step, in another widely-adopted framework, goes on to lay out four system conditions, derived from the laws of thermodynamics, through which such a state can be achieved:

In a sustainable society, nature is not subject to systematically increasing...

1. concentrations of substances extracted from the Earth's crust,
2. concentrations of substances produced by society,
3. degradation by physical means

and, in that society. . .

---

<sup>1</sup> Throughout the guide, the term “product” is used to describe the object being designed, whether an actual consumer product, machined part, piece of equipment, or other component or assembly.

<sup>2</sup> Our Common Future, Report of the World Commission on Environment and Development, World Commission on Environment and Development, 1987. Published as Annex to General Assembly document A/42/427, Development and International Co-operation: Environment August 2, 1987.

4. there are no structural obstacles to people's health, influence, competence, impartiality and meaning.<sup>3</sup>

### Scope of sustainability

As can be seen in the definitions above, sustainability represents a balanced interaction between the human-built and natural worlds. This interaction is often expressed as having three components: environment, social equity, and economy. The relationship between each of these elements is often represented as either a Venn diagram, with sustainability at the intersection, or as concentric circles, reflecting a layering of domains. This second case reflects the more realistic perspective that a healthy economy depends on a healthy society, both of which rely on a healthy environment. Sustainability occurs when all three are thriving.

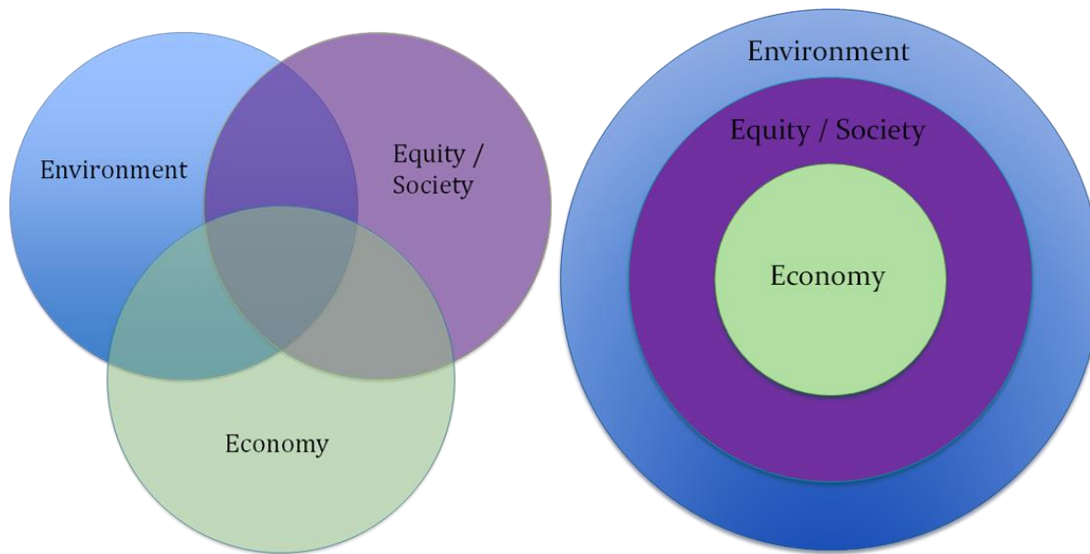

### Sustainable Company

Sustainable companies reflect the same balance of economic, social, and environmental responsibility. They exist as business entities, but are a part of a system that relies on a healthy dynamic of man-made and natural elements. At their most basic level, businesses take inputs, process them (adding value), and generate outputs. That gives us the ideal of a truly sustainable company to strive for:

A truly sustainable company is one that:

- Uses the waste of other processes as its input, and minimizes or eliminates the use of virgin materials extracted from the earth;
- Creates output that can be used by other processes or returned to a natural state, and eliminates waste that can't be used or returned to a natural state;
- Uses the least amount of energy to achieve the desired outcome, and uses energy ultimately derived from renewable sources.

---

<sup>3</sup> <https://thenaturalstep.org/approach/the-system-conditions/>

The value companies generate has traditionally been measured in purely financial metrics. However, it is becoming more common to reflect the value generated as a “triple bottom line.” Whether represented formally as a Corporate Social Responsibility report or more informally, companies interested in being sustainable now focus on the triple bottom line of people, planet, and profit.

Sustainability manifests itself in companies at a variety of levels, including:

- Strategy – Some companies decide what to make or do based on sustainable business ideals. Stonyfield Farms has made social and environmental responsibility a key part of its business strategy since it began.
- Supply chain & value webs – Walmart requires its suppliers to evaluate and disclose the full environmental impact of their products. There continues to be increased attention to so-called industrial ecology, which analyzes the material and energy flows within whole industrial systems, often extending far beyond the domain of a single business.
- Operations – Decisions about how to make and move products increasingly reflect environmental impacts. In the case of the floor covering company Interface, what has become one of the real sustainable business success stories started with rethinking the social and environmental impacts of their operations.<sup>4</sup> In many cases, companies have instituted Environmental Management Systems (EMS) have operationalized the tracking, documentation, and reporting of environmental impacts by the business. There is even a specific ISO standard (ISO 14001:2015) governing EMS.
- Product development & design – Companies have incorporated sustainability into their new product development process in ways ranging from specifically creating “green” products (e.g., Welford, with its Aurora biodegradable clothing line<sup>5</sup>) to the reduction of the environmental impact of its “regular” products (e.g., Apple’s use of a recyclable aluminum enclosure for its Mac Pro computer).

The majority of this guide will focus on product-level sustainability considerations, but it’s helpful to keep in mind that sustainability isn’t the domain of just one part of the business. In fact, a truly sustainable product can only exist within the context of a much broader system that supports its positive impact on people, planet, and profit.

## The Many Faces of Sustainable Design

Now that you have a bit of background on sustainability, let’s talk about sustainable design. Sustainable design is the term we’ve chosen to represent the intelligent application of the principles of sustainability to the realm of engineering and design. This guide focuses on products and similar manufactured components, but the same principles can also apply to architecture, civic planning, and other realms of the “built.”

Furthermore, “sustainable design” is just one term used to describe the use of sustainability principles in the design and development of commercial and industrial products. Other often-used terms include sustainable engineering, environmentally sustainable design, eco-design, and green design. All are essentially synonymous for most purposes.

---

<sup>4</sup> For more on Interface, see <http://www.interfaceglobal.com/Sustainability.aspx>

<sup>5</sup> <https://www.welfordshop.com/C2C.html>

There are however several terms related to this topic that have distinct meanings. Designers interested in sustainability-focused tools and techniques will find these concepts useful to at least know about, if not incorporate in their work. For more information on each, see the Appendices.

### Design for Disassembly

Sometimes shortened to DfD, this is a design approach that enables the easy recovery of parts, components, and materials from products at the end of their life. Recycling and reuse are noble intentions, but if a product cannot be disassembled cleanly and effectively they are impossible, or at least cost prohibitive to achieve.

If you'd like to learn more about DfD, there's a really great set of Design for Disassembly Guidelines (PDF) produced Pensar.com<sup>6</sup>, and a similar set of rules and case studies for building produced by the City of Seattle<sup>7</sup> (WA, USA) and others called Design for Disassembly in the Built Environment<sup>8</sup> (PDF).

### Design for the Environment

The U.S. Environmental Protection Agency created the Design for the Environment (DfE) program in 1992 to decrease pollution and the human and environmental risks that it entails. It recognizes consumer and industrial & institutional products deemed to be safer for human health and the environment through an evaluation and product labeling program. Furthermore, the program defines best practices in a variety of industries, and identifies safer chemical alternatives.

You can learn more at EPA's DfE website, <https://www.epa.gov/saferchoice/design-environment-programs-initiatives-and-projects>.

### Product stewardship

Also known as extended product responsibility (EPR), this approach is based on the principle that all those involved in the lifecycle of a product should share responsibility for reducing its environmental impact. It often results in voluntary partnerships among manufacturers, retailers, government, and non-government organizations to set up effective waste-reduction systems and practices. For an example of product Stewardship and EPR, you can visit Canada's extended producer responsibility website<sup>9</sup>.

### Cradle to Cradle

William McDonough and Michael Braungart popularized the notion that product lifecycles should be considered not as cradle to grave, but as cradle to cradle. The key idea here is that there is no such thing as a "grave" at the end of use, since everything goes somewhere. As they say, there is no such thing as "away." Given that, in order to be sustainable all of the elements of a product that has reached the end of its useful life should be designed to go somewhere where it can serve as the input to another system, a concept often characterized as "waste = food." While product development processes may focus on cradle to gate, cradle to grave, or even gate to gate plans, effective lifecycle planning needs to find ways to close all possible loops.

---

<sup>6</sup> <https://pensar.com/design-for-disassembly/>

<sup>7</sup> <https://www.lifecyclebuilding.org/docs/DfDseattle.pdf>

<sup>8</sup> [https://www.epa.gov/sites/production/files/2016-03/documents/design\\_for\\_disassembly\\_in\\_the\\_built\\_environment.pdf](https://www.epa.gov/sites/production/files/2016-03/documents/design_for_disassembly_in_the_built_environment.pdf)

<sup>9</sup> <https://www.canada.ca/en/environment-climate-change/services/managing-reducing-waste/overview-extended-producer-responsibility.html>



Learn more about the concept from McDonough and Braungart’s coauthored book *Cradle to Cradle: Remaking the Way We Make Things* ([amazon link](#)), and from the dedicated C2C page on their for-profit company’s website.

### Biomimicry

Nature has spent millions of years developing some very interesting and effective solutions to a wide range of design challenges. Biomimicry is “the imitation of natural biological designs or processes in engineering or invention.”<sup>10</sup> Such inspiration comes in two forms, as either “challenge to biology” or “biology to challenge.” In the first case, a design challenge exists and designers search nature for potential solutions. The second case entails starting with an interesting biological property that researchers or scientists attempt to apply more broadly or commercialize. Note that just because a solution is based on nature doesn’t mean that it’s inherently healthy or sustainable. For instance, nature has created plenty of toxic substances that could be extremely harmful if misapplied.

Read more about this science, and the work of some “biomimics”, by picking up a copy of Janine Benyus’ book *Biomimicry: Innovation Inspired by Nature* ([amazon link](#)) or by visiting the website of the not-for-profit Biomimicry Institute.

### Green chemistry

Green chemistry focuses on reducing the generation and use of hazardous chemicals, decreasing pollution at its source. Paul Anastas and John Warner published the *12 Principles of Green Chemistry* in 1998 and set out the following design goal<sup>11</sup>:

Chemical products and processes should be designed to the highest level of this hierarchy and be cost-competitive in the market.

1. Source Reduction/Prevention of Chemical Hazards
2. Reuse or Recycle Chemicals
3. Treat Chemicals to Render Them Less Hazardous
4. Dispose of Chemicals Properly

Learn more about Green Chemistry by reading Anastas and Warner’s coauthored book, *Green Chemistry: Theory and Practice* ([amazon link](#)), or by visiting the website of Dr. Warner’s for-profit company, the Warner Babcock Institute for Green Chemistry.

### Green marketing

Many companies find that promoting the environmental responsibility, or even just the benefits, of their products can be a powerful marketing angle. Touting the “green” aspects of existing products, processes, or systems has become almost the standard in many industries. Some companies’ messages actually outstrip their reality, leading to what is generally called “greenwashing.” As will be discussed later in the guide, there are now quite strict guidelines issued by the Federal Trade Commission about making “green” claims. When talking with sales and marketing people in their company, product designers will find it helpful to know what benefits of their sustainable design and engineering efforts can be claimed publicly.

---

<sup>10</sup> <https://www.merriam-webster.com/dictionary/biomimicry>

<sup>11</sup> *Green Chemistry: Theory and Practice*, Oxford University Press (1998)

Learn more about Green Marketing by viewing this short video on the topic produced for Sustainable Life Media's SustainableBrands Boot Camp<sup>12</sup>, or view the FTC's Green Guides and related resources at <https://www.ftc.gov/news-events/media-resources/truth-advertising/green-guides>.

## Chapter 3: Making Theory Matter - Initial Analysis Decisions

### Your influence is critical

In the midst of the myriad sustainability tools, techniques, global and local activities, and corporate initiatives the product designer plays a key role. This person has an impact in the pivotal stage where decisions are made about what inputs are needed, how they must be processed, what the product's lifecycle looks like, and what its end of life looks like. Engineering for sustainability early in the design process creates a trajectory that can lock in the benefits from the beginning, whereas leaving environmental impact considerations for later stages creates costly clean-up and accommodation efforts. For instance, a product designed for easy disassembly requires much less effort to convert into recyclable and reusable components than one designed as a single module requiring energy-intensive end-of-life processing. The following graph reflects the advantages of making sustainability a priority as early in the design process as possible.<sup>13</sup>

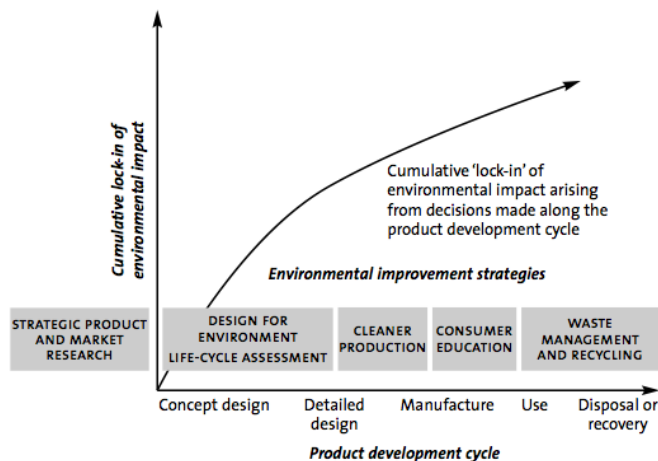

There are obviously many decisions affecting sustainability over which design engineers have little or no influence. For instance, it's usually not solely up to the designer where a component is manufactured, what transportation modes will be used to deliver it to customers, what materials suppliers use, and so on. Even so, what engineers can do to influence a product's environmental impact has far-reaching implications. In his book *The Total Beauty of Sustainable Products*, Edwin Datschefski writes, "Design is the key intervention point for making radical improvements in the environmental performance of products. A 1999 survey by Arthur D. Little revealed that 55 per cent of senior executives in industry singled out design as the most important mechanism for their companies to tackle sustainability."<sup>14</sup>

<sup>12</sup> <https://go.sustainablebrands.com/resources-sb-bootcamp>

<sup>13</sup> *Design + Environment: A Global Guide to Designing Greener Goods*, Greenleaf Publications (2001), p. 14

<sup>14</sup> *The Total Beauty of Sustainable Products* - Edwin Datschefski, RotoVison SA, Switzerland, 2001

Along with influencing the product development process, it is often the designer's identification of a more responsible choice that can cause changes in other areas towards creating a more sustainable company overall.

### A sustainable design challenge

Let's start off with an example—something you can look at from all angles, at least virtually. We'll also introduce a character to champion this example.

Our first protagonist is a producer of paper and plastic products for the public, whose name is Priscilla. Her story illustrates many of the concepts we'll be up against.

*Priscilla was tasked with a seemingly straightforward question:*

*How can we make our disposable drinking cups greener?*

*Priscilla's first thought, especially given her background as a polymer engineer, was that this was going to be a game to find the least-impactful plastic polymer with the desired properties... but we're getting ahead of ourselves.*

*First, here's a picture of the cup in question that Priscilla was starting with:*

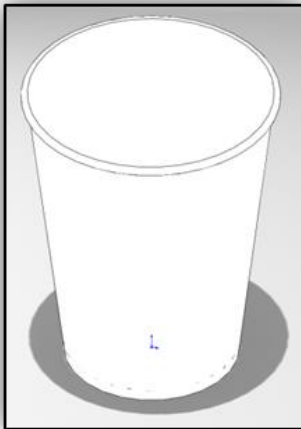

If you're a SOLIDWORKS user, you can the required files here ([https://files.solidworks.com/sustainability/Guide\\_cup\\_files.zip](https://files.solidworks.com/sustainability/Guide_cup_files.zip))

Now, let's get down into the details of what environmental impact assessment looks like. We'll see that examining the environmental impacts of this cup was anything but simple.

### Environmental Impact Assessment Tools & Techniques

#### Sustainable design is relative

First, you'll notice we said we wanted a greener drinking cup. There is no such thing as a "sustainable" or "green" product, only a more sustainable or greener one. In fact, a green product is one that's never made -- the most sustainable solution is to avoid making unnecessary items altogether.

*When Priscilla learned the "Sustainable design is relative" concept, she stopped to think about her product. Were disposable drinking cups really necessary? Shouldn't Priscilla be encouraging her*

*consumers to use reusable cups instead? That was fine in theory, but reusables were made in another division and in another country. So, thought Priscilla, let's try to make the best disposable drinking cup we can, and revisit the deeper product redesign later. After all, even if Priscilla succeeded in encouraging her customers to buy reusables, they weren't going to stop buying disposable cups overnight.*

For those products that we've decided are necessary, everything has impacts of some sort. The basic purpose of sustainable design is to find ways to reduce those impacts, and by doing so find a more sustainable solution. This section describes ways to determine what "more sustainable" looked like for Priscilla.

### What Am I Comparing?

*Priscilla's next thought was: "more sustainable than what?"*

Designers who want to decrease a product's environmental impact need to have some way of evaluating what difference their choices make. The only way to evaluate whether a design is more sustainable is to see how its impacts compare with other options, such as an alternative design, a previous version, a benchmark, or an impact goal.

Throughout this guide, the term product has been used to describe the object of the designer's work. When it comes to determining environmental impact, it's important to specify a unit of analysis. Relative comparisons only work if there is a common basis. In some cases this might be quite straightforward, such as when it's two generations of the same design or when faced with a simple material substitution. However, in most redesign opportunities, it's necessary to specify a common "product unit" for the analysis.

An often-used way of handling this is to identify a functional unit. Instead of looking at a product as an item, it can be seen as a way for a certain function to be performed. In order to compare two different product systems, it's necessary to choose a measure of the function of the systems that is consistent between the two. For instance, for a coffee maker it might be cups brewed, for laundry detergent it could be washing cycles, for paint it could be surface protection over time. This way, it's possible to assess the impact of various ways to perform a specific function, without being constrained by differences in the forms of the designs.

*"Well, that's easy," thought Priscilla. "My cup's purpose is to hold liquid." But when she thought about all the products designed to hold liquid -- detergent bottles, soda cans, mop buckets -- Priscilla realized she had to narrow down this purpose to define the functional unit. She decided that her cup's functional unit was sixteen ounces or about 500 mL of (cool) liquid that could be poured in or out—or even better, 1600 ounces, equaling the volume of a pack of 100 cups. Now she could compare her bag of cups with all the other products imaginable that could hold this amount of cool liquid (and pour it in and out) and find the most sustainable option.*

### What Am I Measuring? The Three Choices of Environmental Assessment

Product sustainability is not only relative, it's multidimensional. There is no single, universal indicator of sustainability (no, not even carbon). The appropriate impact metrics and dimensions on which products are compared can differ significantly, depending on the purpose of the evaluation. Impact measurement creates the key dashboard for sustainable design, so it's important to choose an assessment approach that will generate information consistent with its intended use.

The appropriate technique for evaluating the environmental impact of a design depends on the answers to the following three questions:

1. **What impacts do you care about?** Does toxicity matter? Water use? Only CO2 equivalents?
2. **What is the scope of the assessment?** How far up and down the supply chain does it go? How much of the product’s lifecycle should it reflect? What is the unit of analysis for the assessment? Is it for a component, an assembly, a product, a system?
3. **What types of metrics are appropriate for your purposes?** What will the assessment information be used for, and by whom? Is rigorous detail necessary, or is a “rough idea” good enough?

The following figure lays out these choices graphically, using examples of some of the impacts, scope elements, and metrics that might be used. The sections that follow will explore each of these elements in more depth and give examples of the kinds of assessment techniques appropriate at each level.

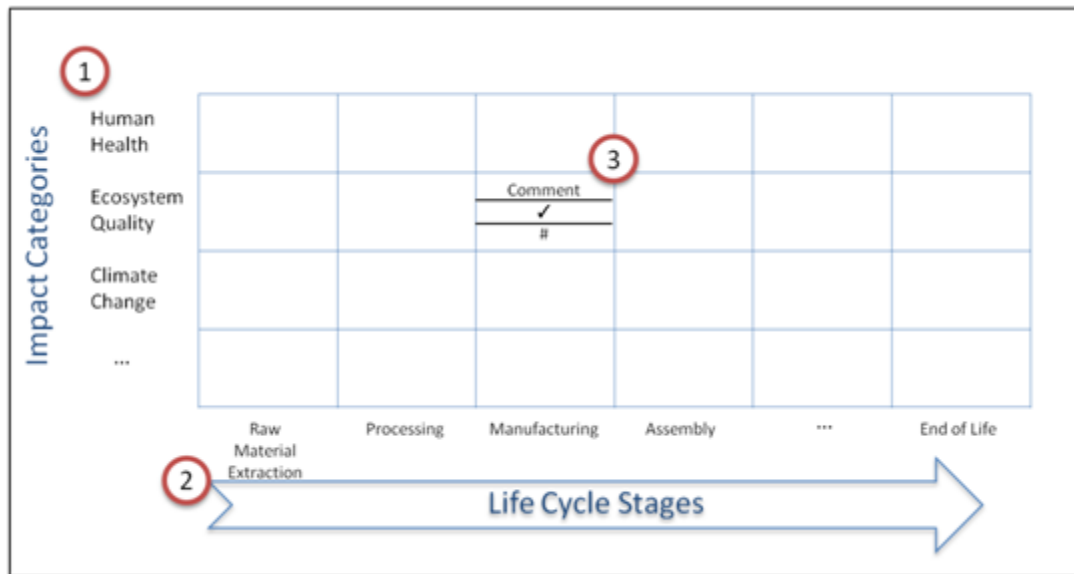

*“This is pretty intense,” thought Priscilla. “I’m going to call up my friend Tom and talk to him about sustainable engineering and my little cup. Maybe Tom has been through this process before.”*

*As luck would have it, Tom was going through an identical exercise with a product of his own. Tom is a tinkerer of tiny toys for tots and toddlers, and now he was toying with the idea of making a greener holiday gift for his wee customers.*

*Here’s the toy that Tom showed Priscilla:*

*Download the model to play along with this example ([https://files.solidworks.com/sustainability/Guide\\_fire\\_engine.zip](https://files.solidworks.com/sustainability/Guide_fire_engine.zip)).*

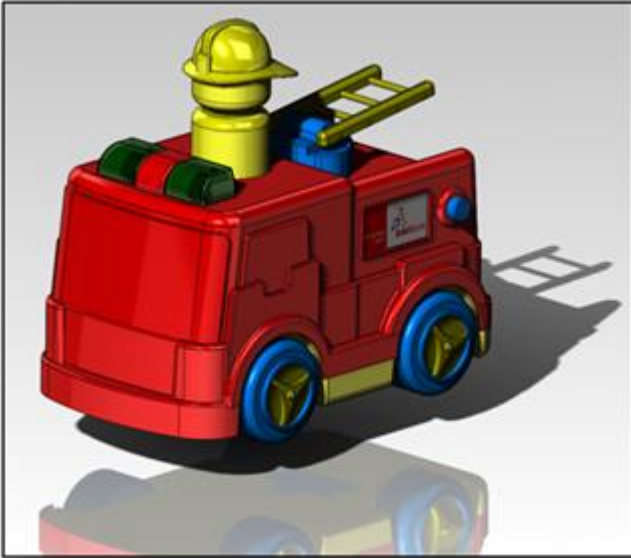

*“It’s a pretty simple toy,” Tom told Priscilla. “The child pushes it around, and at the push of the button, the lights flash and the siren sounds. They can also pull the fireman out of the truck.”*

*“I had to think for a while about the functional unit that I was using for environmental comparisons,” continued Tom. “After all, this toy is clearly more impactful than other toys—say, some simple plastic blocks of similar size. After all, my toy uses a battery. But I’ve noticed that my own kids will play with a toy a lot longer if it does something—like having flashing lights. So I decided that my functional unit was a children’s toy with interactive components, which can be played with on the floor. So my question is:*

*“How can I make a greener children’s toy?”*

*“I’m at the stage now where I’m making my three measurement choices,” Tom finished. Perfect, thought Priscilla.*

#### Choice 1: Environmental Indicators

There are a wide range of environmental impacts that can be assessed. However, it's not always necessary to try to cover many, or even some, of these impacts if you're mainly interested in one impact measure, or environmental indicator. For instance, there's a lot of attention on greenhouse gas (GHG) emissions these days, due to their association with climate change. If the carbon footprint resulting from these emissions is the only impact your organization or your customers are focused on, it would be unnecessary to spend time assessing impacts on such things as air quality or human toxicity; measuring your product's carbon footprint would suffice. So, step one is to determine which impacts should be measured based on the purpose of the assessment and how its data will be used.

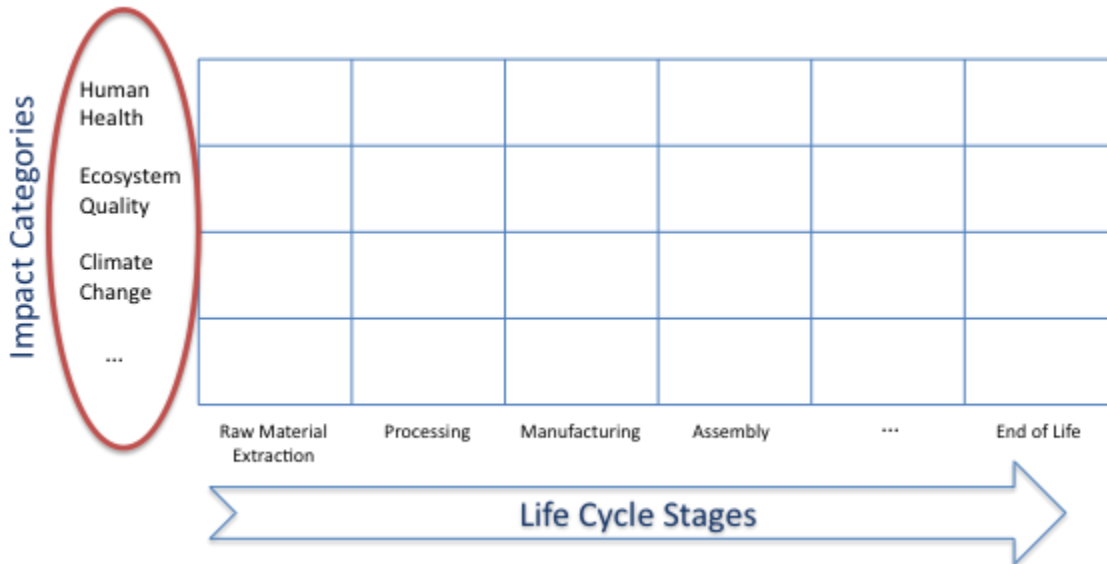

### Five Categories of Impact

How to choose among the dozens of different types of environmental impacts? We'll start with grouping some commonly used environmental impact categories into five major domains:

1. natural resource depletion,
2. air impacts,
3. terrestrial & aquatic impacts,
4. climate effects, and
5. human health.<sup>15 16</sup>

This section will describe these different environmental effects that Priscilla and Tom can choose to measure.

### Natural Resource Depletion

This first domain reflects the many ways human activity uses up the Earth's natural resources. "Depletion" means that those resources are no longer available for further use in their highest-value forms.

### Water Use

A water "footprint" primarily refers to the amount of fresh water being used or consumed which then must be processed back to its fresh state (water quality issues are covered by other impact categories).

<sup>15</sup> Jolliet, O., Margni, M., Charles, R., Humbert, S., Payet, J., Rebitzer, G. and Rosenbaum, R., 2003. IMPACT 2002+: A New Life Cycle Impact Assessment Methodology. *Int J LCA* 8 (6), 324-330. Article

<sup>16</sup> Adapted from "Life Cycle Assessment: Principles and Practice," Scientific Applications International Corporation, EPA/600/R-06/060 (May 2006), pg. 49.

Water is the only resource that is both renewable and finite. All of the water that was ever on Earth is still on Earth, but the breakdown of its location, physical state (water, vapor or ice), and salinity can limit its usefulness as a resource. In fact, after oil, many people believe that water will become the resource with the most highly valued access rights, which has significant social and environmental-justice implications.

### **Mineral Extraction**

Mineral deposits can't be renewed. Once a mineral deposit (like iron ore) is mined, it doesn't return to the earth as ore, no matter how much it's reused or recycled. There's only a finite amount of each mineral, so any used now will not be available for future generations to mine.

### **Land Occupation/Use**

Land can't be depleted, really (ground pollution is covered later), but since a given acre can only be used for a limited number of purposes, land scarcity can be a real issue. Land can also become unusable, or at least less valuable, due to physical changes such as erosion.



A decrease in available land can impact a wide variety of systems, including agriculture, civilization, and biodiversity – the amount and variety of life that the land can support.

### **Non-Renewable Energy**

While there are a variety of non-renewable natural resources used for energy, the ones that usually get the most attention are oil, coal, and natural gas. This non-renewable energy impact includes the energy (electricity or fuels) used during the product's manufacture and use, and can even go one step further to include the upstream energy required to obtain and process the energy consumed in the product's lifecycle. Efficiencies in energy conversion (e.g. power, heat, steam, etc.) can also be factored in. The non-renewable energy demand can also include a measure of the embodied energy of the materials—that is, the energy that would be released if the product were burned.

### *Air Impacts*

The Earth is wrapped in a layer of gases mixed in proportions necessary to sustain life on the planet. There are several ways humans affect those proportions, with far-reaching results. (Effects to the climate are included in a separate domain.)

### **Air Acidification**

Burning fuels creates sulfur dioxide, nitrous oxides, hydroflouric acid, ammonia, and other acidic air emissions. This causes an increase in the acidity of rainwater, which in turn acidifies lakes and soil. These acids can make the land and water toxic for plants and aquatic life, and can leach life-sustaining minerals from the soil. Acid rain can also slowly dissolve manmade building materials, such as concrete—or these statues seen here.

### **Photochemical Oxidation**



Most people are very familiar with this impact—especially when it's called by its common name of "smog." Caused by the emission of air pollutants such as non-methane hydrocarbons, this effect results in decreased visibility, eye irritation, respiratory tract and lung irritation, and vegetation damage.

### **Ozone Layer Depletion**

Not long ago, the holes growing in the ozone layer were the top environmental concern. While quick action has slowed, and in some cases reversed, the damage, ozone layer depletion is still a concern. Caused primarily by the emission of chlorofluorocarbons (CFCs), hydrochlorofluorocarbons (HCFCs), halons, and methyl bromide (CH<sub>3</sub>Br), the thinning of the atmosphere's ozone layer allows increased ultraviolet radiation to reach the earth. This radiation can cause cancer in animals and decreased plant and algae viability.

#### *Terrestrial & Aquatic Impacts*

Several types of impacts directly affect land and water quality.

### **Water Eutrophication**

Eutrophication occurs when an overabundance of plant nutrients are added to a water ecosystem. Nitrogen and phosphorous from wastewater and agricultural fertilizers causes an algal bloom (explosive growth of algae), which then depletes the water of dissolved oxygen—a situation known as hypoxia—resulting in the suffocation of aquatic life.

### **Aquatic Ecotoxicity**

While eutrophication occurs due to an excess of nutrients, ecotoxicity results from the presence of poisons in the water. This is generally caused by chemicals being dumped or seeping into lakes and rivers. It results in decreased aquatic plant and insect production and biodiversity, as well as impacting water drinkability.

### **Terrestrial Ecotoxicity**

Toxins present in soil cause decreases in wildlife and plant production and biodiversity. While some of these toxins may be introduced from airborne or aquatic sources, many are the result of direct human application or through leaching from industrial processes or waste accumulations

#### *Climate Effects*

The global climate is the result of myriad interacting systems. In many ways all of the other impacts have some influence over the climate. However, one climate effect in particular has been identified as a key factor in shaping the future of life on Earth. Climate change, sometimes called global warming, is one of the most commonly identified impacts of interest.

### **Climate Change/Global Warming**

Carbon dioxide (CO<sub>2</sub>), methane (CH<sub>4</sub>), and other so-called greenhouse gases resulting from burning fossil fuels accumulate in the atmosphere, trapping solar heat which in turn increases the earth's average temperature. A product's climate change impact is often referred to as its "carbon footprint" because global warming potential is usually measured in units of carbon dioxide equivalent (CO<sub>2</sub>e). It is widely understood that global warming is the cause of such problems as loss of glaciers, extinction of

species, soil moisture loss, changes in wind and ocean patterns, and more extreme weather, among others.

### *Human Health*

While the other impact domains affect humans in many ways, they focus on the Earth's biosphere as a whole. This group of impact categories is human-centric.

#### **Human Toxicity**

Toxic chemicals released to the air, water, and soil enter the human body through breathing, ingestion, and through the skin. Whether cancer-causing agents (carcinogens), substances that can cause birth defects (teratogens), or other pathogens, the net result is an increased likelihood of human sickness and other negative health effects.

#### **Respiratory Inorganics**

Many organic causes of respiratory problems are covered by some of the general environmental impacts already covered (e.g., photochemical oxidation). Respiratory inorganics are particulate matter, often resulting from the burning of fossil fuels emitting sulphate and nitrate aerosols. This particulate matter causes breathing difficulties.

#### **Ionizing Radiation**

Ionizing radiation is what most people are thinking of when they talk about radiation exposure. It is radiation that has enough energy to ionize atoms or molecules. Exposure can damage living tissue, resulting in cancer, radiation sickness, mutation, and even death.

The impact categories described above represent most of the major ones that you are likely to come across, although occasionally with different names or classifications. While all may seem important, each one requires data collection and reporting, which may or may not be feasible given the time and intention of the sustainability assessment. There are trade-offs in the value of including a broad range versus just focusing on one or two, a difference that multiplies depending on how many stages of the lifecycle fall within the assessment's scope.

### *Choice 2: Scope*

The second major consideration in assessing the sustainability of a product is the scope of analysis. For products, the scope is usually described by how much of its lifecycle is included in its impact assessment.

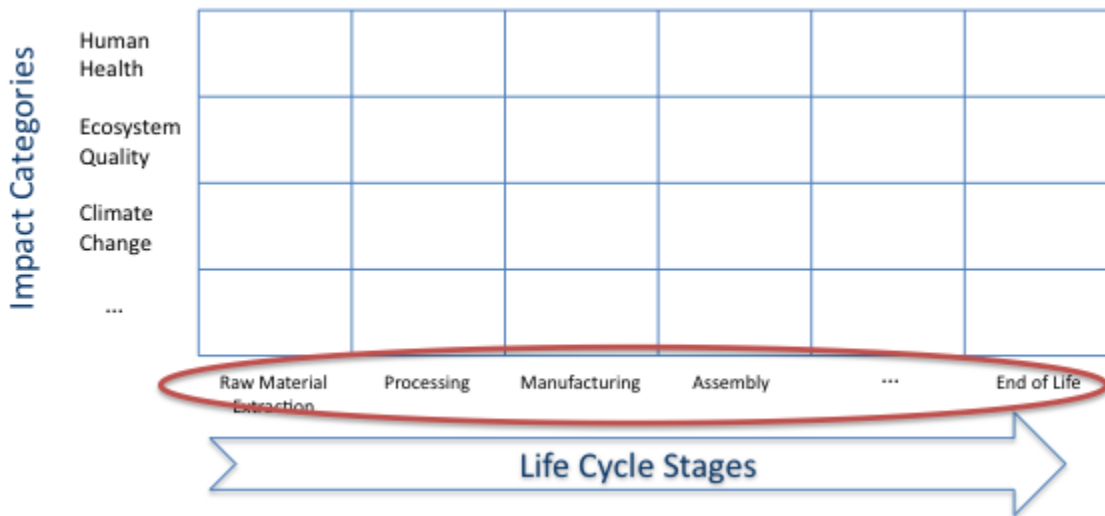

### Lifecycle Stages

As with impact categories, there is not a single standard set of lifecycle stages, although there are certainly some that are most commonly used. In general, the full lifecycle of a product can be measured in five to seven stages:

#### Raw Material Extraction

This includes the energy and other resources used to acquire the basic materials used in the product, whether through mining ore, harvesting timber, extracting oil, etc. This stage can include harvesting materials from recycled sources if they are in the form of raw materials.

“My cup is plastic, so it starts with oil extraction,” said Priscilla.

“A lot of my toy does, too,” replied Tom. “But it also has some metal components, so that would include mining the ore.”

#### Material Processing

Raw materials are converted into forms used for manufacturing during this stage. It covers the processes required to make steel, copper, plastic feedstock, paper, gasoline, and the like.

“OK, so the oil for our plastics is then refined into the various hydrocarbon fractions to make the different plastic resins,” said Priscilla, idly sketching a distillation column.

“And the ores are refined into metals by melting or burning off impurities,” added Tom, wondering why Priscilla was sketching a missile silo.

#### Part Manufacturing

This stage covers single, or at least simple, part manufacturing. Common processes include injection molding, metal stamping and machining, weaving, and milling.

“My cup is made from PET plastic—polyethylene terephthalate. This is where the PET is injection-molded into a cup shape.”

“The plastic that makes up most of my toy is molded, too, but from ABS plastic. The siren sound comes from a little speaker component that I purchase; I’m not sure what’s in it, but I’m sure there’s a lot of copper, so I’ll just model it as a copper part. The spring is made of a steel alloy—probably regular carbon steel.”

### **Assembly**

In many cases, products need to be assembled using processes that go beyond the creation of individual components. Because this is usually the first stage that brings together a disparate assortment of materials (e.g., a plastic handle and a metal container), environmental impact assessments significantly increase in complexity.

“I don’t really have any assembly steps,” said Priscilla, “since my cup is molded in a single pass from a single material.”

“I do have some assembly steps, but most of the parts just snap together. And of course, the battery is wired up to the siren and the lights.”

### **Product Use**

Any energy used, emissions generated, other resources affected directly by the product during its actual use are counted during this phase. This includes waste that occurs in the context of a product’s use, such as discarded packaging.

“My product is powered by a person picking it up and drinking from it!” laughed Priscilla. “No product impacts there.”

“Mine isn’t,” Tom sighed. “I guess I’ll take a hit for it using energy from the battery. But aren’t most interactive toys like this one battery-powered?”

### **End of Life**

Once a product is no longer used, it has reached its end of life. This usually means that the product is no longer usable, although there are many examples of end of life coming before end of usability (e.g., paper cups). This stage is usually broken down into three resulting streams: the fraction of a product being sent to landfill, to incineration, and to reuse or recycling.

Priscilla knew that recycling was a big issue for her PET plastic cup. “I guess the recycling rate depends on where the product’s being used,” she said. “I’ll bet it’s higher in Europe than in the US.”

“I’m not so sure about that,” Tom said. “We recycle a lot of our steels and aluminums in the US, if not as much of our plastics. We also landfill more of the rest of the materials, rather than incinerate them, which they favor a bit more in Europe.”

### **Transportation**

Transportation is not typically given as a lifecycle stage, since transportation legs actually occur between each of the lifecycle stages, but it’s an important consideration to account for in the product’s lifecycle impacts. Transportation can be included among the stages according to where it takes place (e.g., the shipping of raw materials to processing centers could be considered a piece of the processing stage). In some cases, transportation may appear as a separate lifecycle component, especially between Assembly

and Product Use for consumer products, since there are typically several stops along the way (e.g., wholesaler, retailer, delivery). No matter how it's handled, it is important to make sure that transportation doesn't fall through the cracks.

"Most of my components are made in Asia," Tom jumped in, "but a couple of them aren't. The speaker comes from Japan, and the acrylic light fixtures come from a little shop in Europe. After the product is assembled in Asia, it's sent by ship to my main market in the US."

"Simple for me," said Priscilla. "The cups are packaged and sent from our factory in Asia and are also sent to the US. I wish we could make them locally," she added, "I'm sure that would be better for the environment."

### System Boundary

Doing environmental assessments can sometimes be like chasing fractals. Product lifecycles intersect a great many processes, some more directly linked to the product than others. Since an assessment can't always cover everything, system boundaries clarify what it will include. It's often helpful to draw a process diagram, and then trace a boundary around what will be measured.

For example, the following figure shows a possible system boundary chart for an assessment of a polystyrene cup, with a functional unit of one cup.

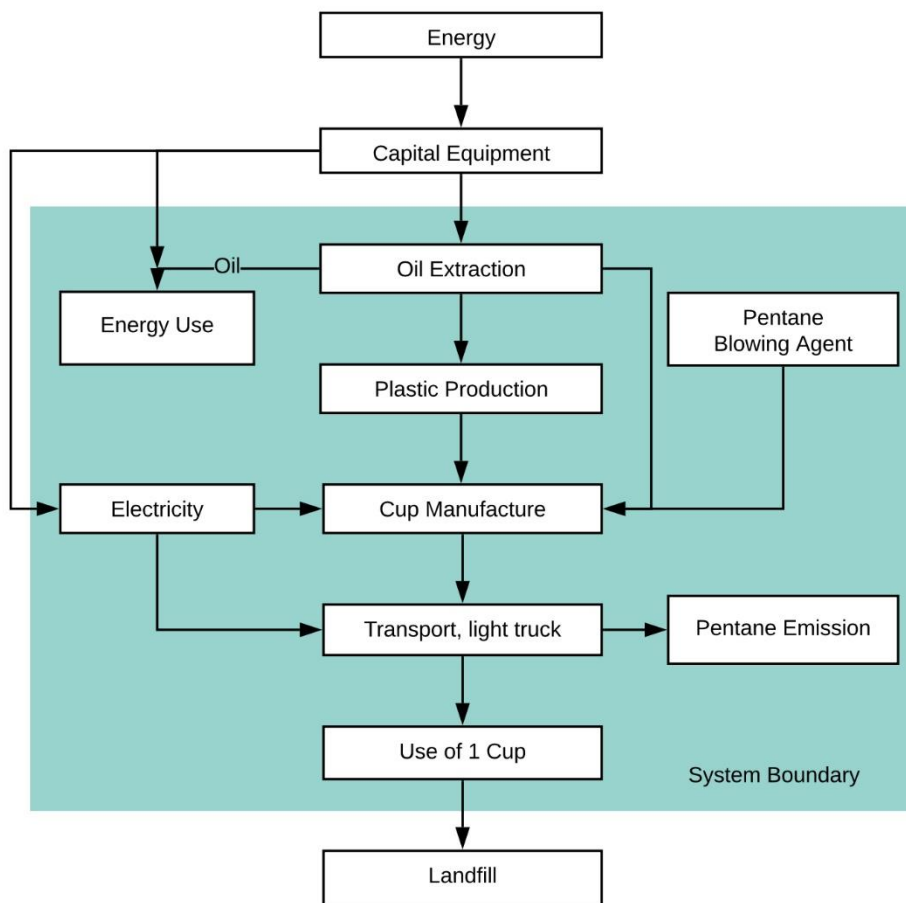

Some of the standard product lifecycle system boundary scopes include

- “Cradle to grave” – Usually denotes all phases from raw materials through disposal.
- “Cradle to cradle” – Like cradle to grave except that it tracks where the product’s elements go after end of use, with special attention to recycling and reuse.
- “Cradle to gate” – Includes part of the product lifecycle, typically either:
  - all upstream phases, not including the assessing company’s own processes; this is used to assess the “environmental burden” of raw materials coming through the door; or
  - all phases through the assessing company’s manufacturing and assembly (the factory gate), bound for the customer, since this is the end of most manufacturer’s ability to directly influence impact.
- “Gate to gate” – A narrowly-scoped lifecycle assessment, focused on only one particular stage or set of stages of the product lifecycle.

Priscilla grabbed a dry-erase marker and sketched out her cup’s process diagram:

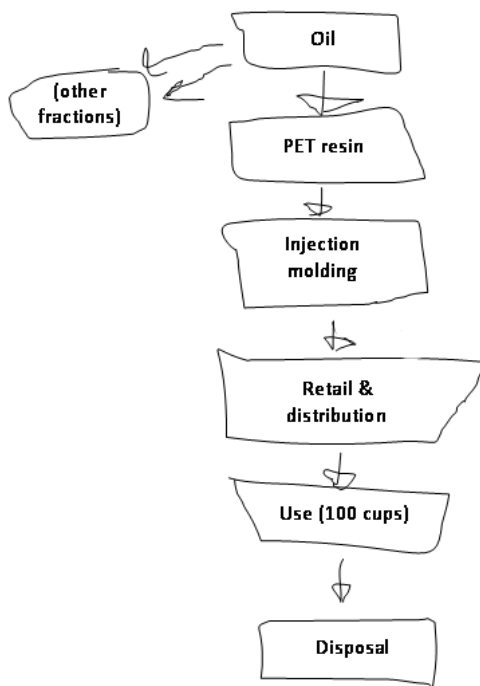

“What about packaging?” asked Tom. “You mentioned that the cups are packed into bags of 100 cups, your functional unit.”

“Oh yeah,” said Priscilla. She added the packaging step to the diagram. “I think the bag is pretty minimal compared to the cups, though,” she said. “So until I get a chance to talk to our packaging group about materials and sizes of the packing materials, I’ll exclude that from my system boundary.” Finally, she grabbed a thick orange marker and drew a box for her system boundary.

Her final sketch was as follows:

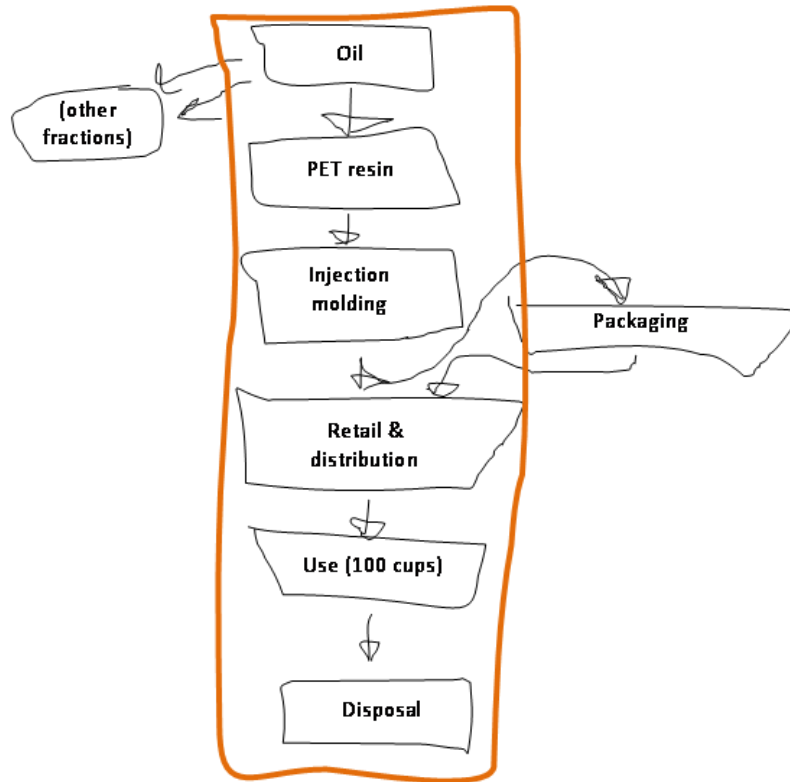

“Mine’s more complex,” said Tom. He stepped to the whiteboard and began to fill his own process steps into Priscilla’s boxes, and add a few of his own:

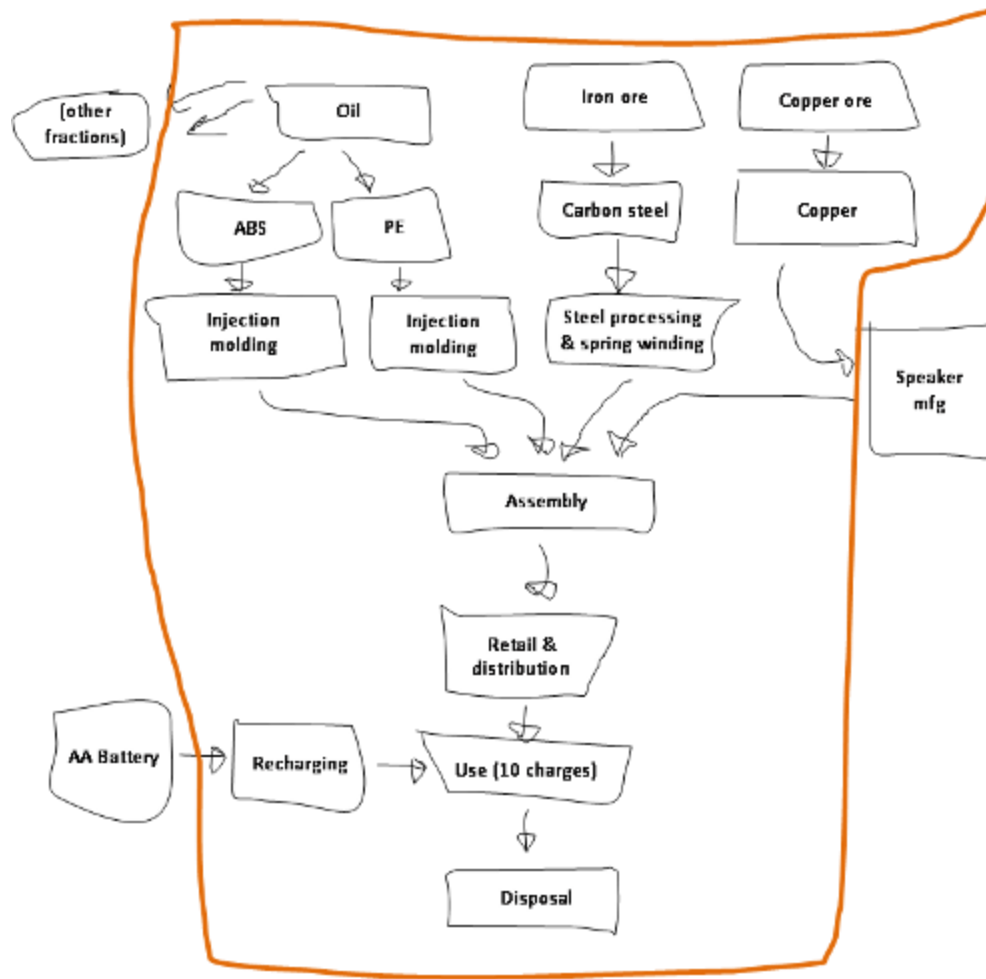

“I’ll have to make some more assumptions,” Tom said, stepping back from the diagram. “I include a rechargeable battery with my toy, and I’ll assume the parent recharges the battery ten times before the kid gets bored with the toy, or outgrows it. But since I want to compare this toy to other interactive ones, I’m going to assume the comparisons are also powered by batteries, so I won’t include that in my system boundary.”

With their lifecycle scopes determined—both were versions of a cradle-to-grave assessment, they realized—and their boundaries drawn, Tom and Priscilla were ready to move to the third and final choice.

### Choice 3: Metrics

Once you’ve determined what impacts you want to focus on and how far up and down the product’s lifecycle you want to assess, the final decision is how accurately you need to measure your selected impacts across your chosen lifecycle stages. Once you’ve determined your choice of metrics, you’ll be able to identify the types of impact assessment tools and techniques that will be most useful.



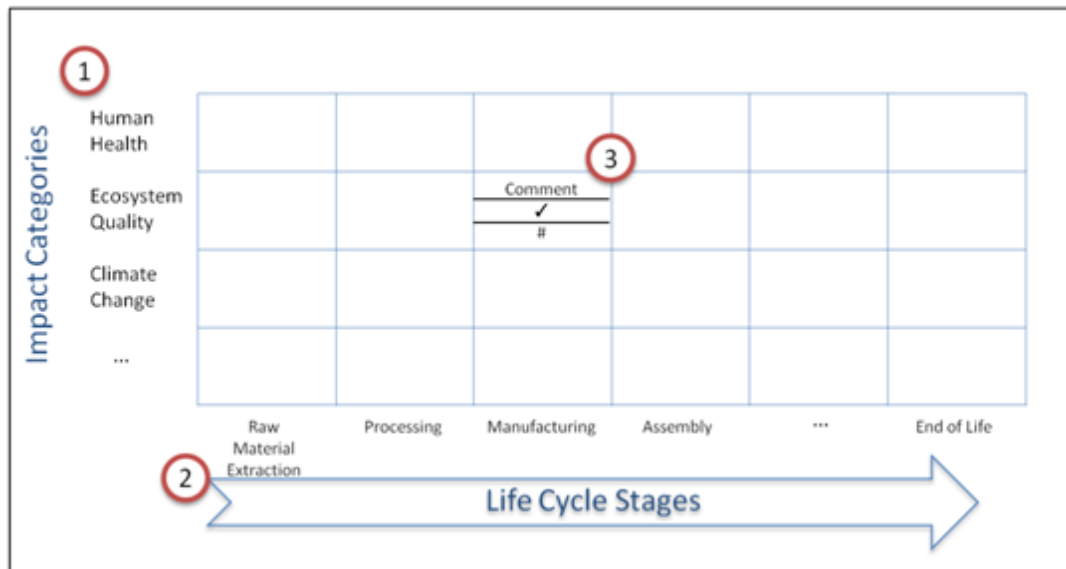

Most metrics fall into one of four categories:

- Comments
- Checkmarks
- Scores
- Measurements

### Comments

The most qualitative, and usually most subjective, way impacts are expressed is through text alone. People can generally describe what they believe an impact will look like, its severity, and so forth at a high level based on their understanding of the product. Comparisons read more like product reviews than detailed technical analyses. This form might be appropriate for a first-pass assessment or as a basis for narrowing down alternatives to be compared. It is not a useful format if continuity and standardization is important because it's so subjective.

### Checkmarks

In some cases, evaluations are based on checklists. The assessment will have certain criteria for each of the categories, which are either met, or not. Is mercury present? Is it certified organic? Is it FSC (Forestry Stewardship Council) certified? Does at least 25% of the energy used come from renewable resources? Checklists like this have the advantage of resulting in evaluations that are easy to compare across a wide range of products. They can be used relatively (i.e., seeing which of the products has more checkmarks) or absolutely (i.e., all of the parts we use must meet a certain threshold). While the checkmarks don't reflect many details or degrees of difference (i.e., the product that uses 100% renewable energy gets the same checkmark as the one that uses 25% if that's the threshold), they may provide enough information to support relevant decisions.

### Scores

Whether in the form of grades, number scales, smiley face icons, or stars, scoring systems have the advantage of the at-a-glance nature of checklists, while also reflecting a more nuanced evaluation of a

product's impact. One of the challenges that comes with nuance however is that someone needs to decide whether something gets an A or a B, 3 stars or 4. In many cases, scoring systems lay out guidelines for what qualifies as an A versus a B so that there is some consistency across evaluators and products. Even so, scores can be subjective and, in some cases, political. Still, a balanced and transparent evaluation process can produce a helpful assessment of the scale of a product's environmental impacts. Such scoring systems are especially useful when a quick assessment is needed to initiate the first discussion across a multistakeholder group.

*"These are probably beneficial for initial assessment," said Tom, "but that's not what I'm after. I need to get a sense of my actual carbon footprint."*

*"I agree," said Priscilla. "I've actually used a couple scorecards, where I learned about issues like manufacturing and eventually recycling PET. Now I'd like to put some numbers to this process... you know, some real measurements."*

### Measurements

The most precise and objective metrics come in the form of specific numbers representing impact levels. These usually take two forms, one impact-specific and the other a standardized conversion into a single proxy number.

#### Impact-Specific

The impact-specific metric is usually expressed in equivalencies of a certain key component of that impact, such as kilograms of CO<sub>2</sub> for global warming. In this case, no matter what the source of the impact on global warming, it would be converted into the equivalent kilograms of CO<sub>2</sub> (often written as "kg CO<sub>2</sub>e," "kgeq CO<sub>2</sub>", "kg-eq CO<sub>2</sub>", etc.) using standardized equations.<sup>17</sup>

Other common equivalency units for several environmental indicators are listed in the table below.<sup>18</sup>

Impact Category	Reference Substance
Human toxicity (carcinogens + non-carcinogens)	kg-eq chloroethylene into air
Respiratory (inorganics)	kg-eq PM <sub>2.5</sub> (particulate matter < 2.5µm ) into air
Ionizing radiations	Bq-eq carbon-14 into air
Ozone layer depletion	kg-eq CFC-11 into air
Photochemical oxidation [= Respiratory (organics) for human health]	kg-eq ethylene into air
Aquatic ecotoxicity	kg-eq triethylene glycol into water
Terrestrial ecotoxicity	kg-eq triethylene glycol into water
Terrestrial acidification/nutrication	kg-eq SO <sub>2</sub> into air
Aquatic acidification	kg-eq SO <sub>2</sub> into air
Aquatic eutrophication	kg-eq PO <sub>4</sub> <sup>3-</sup> into water
Land occupation	m <sup>2</sup> -eq organic arable land·year
Global warming	kg-eq CO <sub>2</sub> into air

<sup>17</sup> The EPA's Greenhouse Gas Equivalencies Calculator is available online at <https://www.epa.gov/energy/greenhouse-gas-equivalencies-calculator>

<sup>18</sup> Adapted from "IMPACT 2002+" LCIA methodology / Dr. Olivier Jolliet, Univ. of Michigan

Non-renewable energy	MJ Total primary non-renewable or kg-eq crude oil (860 kg/m <sup>3</sup> )
Mineral extraction	MJ additional energy or kg-eq iron (in ore)

The next challenge is to determine the impact profiles of substances. For instance, what impact does silver have on ozone layer depletion, eutrication, etc.? There are actually well over a dozen methods for classifying substances.<sup>19</sup> Each maps materials to impacts based on scientific research, with many materials having impacts in multiple categories. The assessment is usually facilitated by software that can take component inputs and calculate allocated impacts based on either actual data gathered or standardized data tables. While there are pros and cons to each assessment tool, some have been adopted more broadly than others. A 2006 survey of 65 lifecycle assessment (LCA) practitioners<sup>20</sup> reported that:

58%\* used GaBi (Sphera)

31%\* used SimaPro (PRé Sustainability B.V.)

11%\* used TEAM (Ecobilan)

Other tools cited:

- openLCA
- Ecochain
- Oneclicklca
- Mobius
- BEES (NIST)
- Umberto (ifu Hamburg)
- Excel-based spreadsheets
- Math package (e.g. MATLAB, Mathematica)

\*percentages include overlap due to usage of multiple tools

### Single Proxy

Because it is difficult to compare the impact of 1 kg-eq CO<sub>2</sub> and 1 kg-eq chloroethylene, for instance, it can be useful to convert all impacts into a single proxy metric. All of the impact-specific equivalencies can be translated into a universal impact factor, often expressed in terms of "millipoints," sometimes after being normalized based on a national or global reference model. Such single-number impact factors are therefore a weighted measurement showing relative impacts across multiple categories. While there are some standard sets of factors, each represents a specific perspective on what to use as a

<sup>19</sup> For a good overview of many of the major methods, see Appendix B: LCA and LCI Software Tools in "Life Cycle Assessment: Principles and Practice," Scientific Applications International Corporation, EPA/600/R-06/060 (May 2006), pp. 74-77.

<sup>20</sup> Cooper, J.S.; Fava, J. (2006), "Life Cycle Assessment Practitioner Survey: Summary of Results", Journal of Industrial Ecology

reference model and how to calculate the conversions. Several of the most widely-used data sets are Eco-Indicator 99 (EI99), EcoInvent, U.S. Life-Cycle Inventory, and CML.

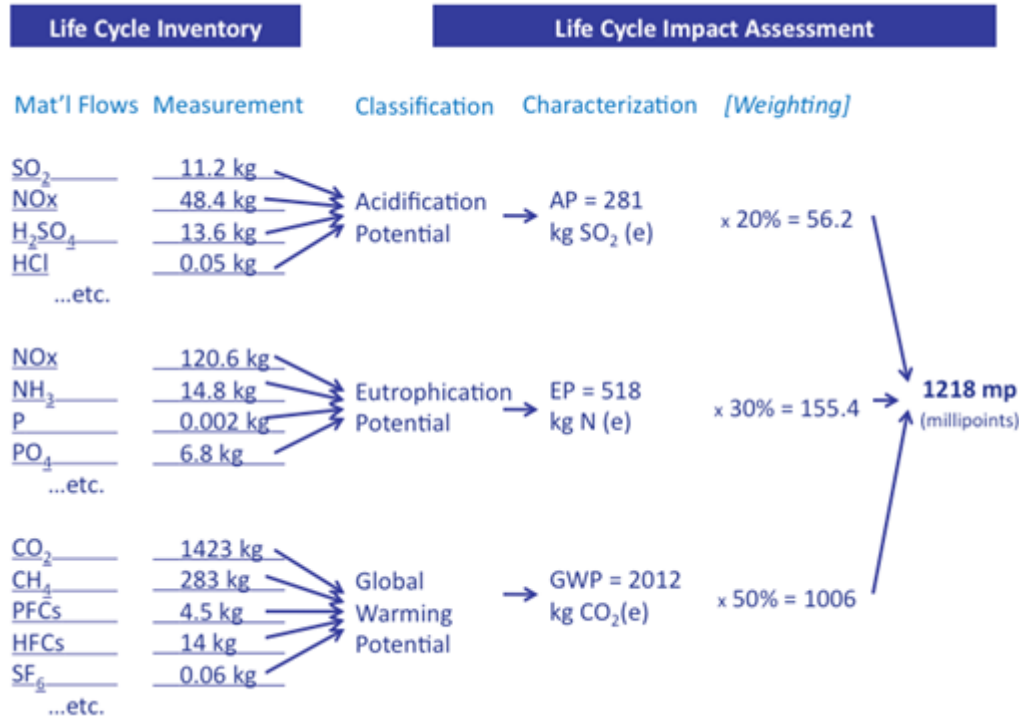

### Weighting

Whenever multiple factors are combined and represented by a single number, some sort of weighting takes place. Sometimes all of the inputs are considered of equal value, but in many cases some inputs are given more influence over the final result than others, reflecting a certain prioritization of the importance of each type of impact. Weighting is more of a political (social, cultural) than a scientific process -- giving, say, more weight to the global warming indicator than to acidification is a values-based decision. Stakeholders may differ significantly on their views about the importance of impacts, as shown in the chart below.<sup>21</sup>

<sup>21</sup> T.G. Gloria, B.C. Lippiatt, and J. Cooper, "Life Cycle Impact Assessment Weights to Support Environmentally Preferable Purchasing in the United States," Environmental Science and Technology, November/December 2007.

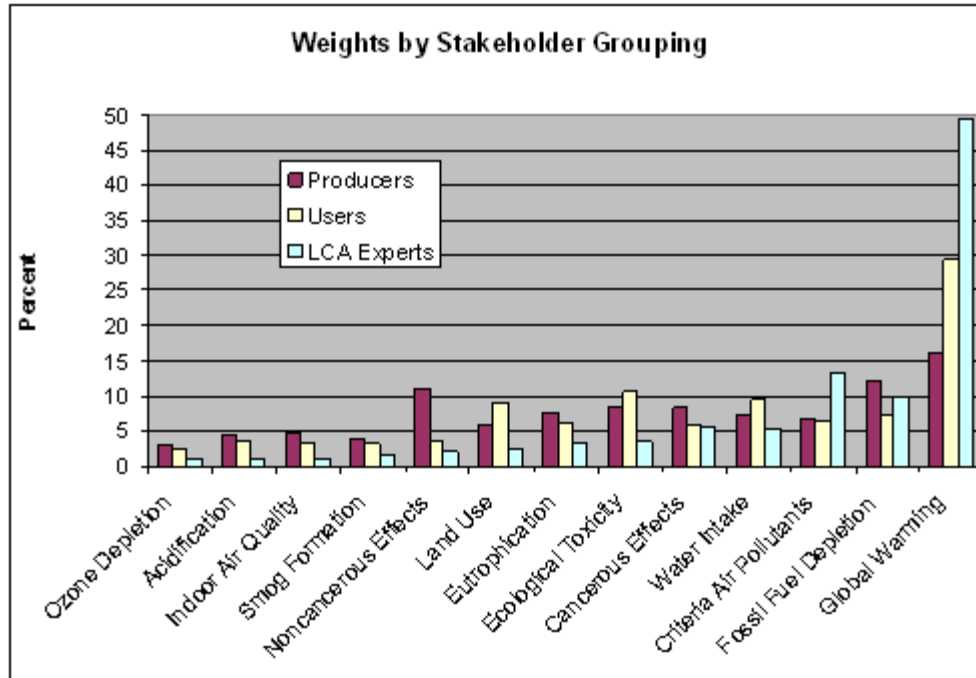

Many practitioners choose to leave the impact scores broken out into categories, with no weighting at all. Although this approach creates a more complicated report, it enables impact comparisons between products on a more granular level.

Weighted "single score" assessments have the advantage of generating one, easy-to-communicate impact number. However, even within the community that supports this approach there are two schools of thought. Some believe that there should be a standard weighting, while others feel that companies should be free to weight impacts as they see fit. One of the advantages of a standard weighting, as is used in the Okala approach among others, is that products can be compared to each other more easily since the single impact scores are only meaningful if compared among products with the same weighting. A second benefit is that companies can't "game" the assessment to make their products look better than they are by emphasizing the areas in which the product does well and decreasing the effect of categories in which the product has problems.

The advantage of variable weighting approaches is that they can be customized to fit an organizations goals and values. For instance, if an organization is making global warming a priority, it may want to weight that category much more heavily as it's assessing the impacts of its products. As long as the weighting remains constant within its own assessments, the disproportionate weight it gives to this category is fine. In some cases, there may be external reasons for giving some impacts priority. For instance, there are some sustainability accounting and reporting standards that focus almost exclusively on greenhouse gas emissions, making it useful for organizations using them to put most, if not all, of the weight on that subset of impact factors.<sup>22</sup>

<sup>22</sup> Carbon footprint standards such as PAS 2050 and the GHG Protocol fit this description.

*"Well, I've chosen five indicators, one from each of the domains of impact. I don't think I want to weight these results together, because I want to choose which ones I'm optimizing for in each design," said Priscilla.*

*"And I'm just measuring a single indicator, carbon, so I won't use any weighted single-proxy results either.*

*"So now that we know our three choices, what tools can we use?"*

## Chapter 4: Putting It All Together

While each of the three environmental assessment choices can be made independently to generate an impact assessment, there are several commonly used approaches. These techniques range from relatively quick, cheap, and low accuracy to much more expensive and time-consuming, but with more rigorous and robust results.

Most sustainability assessments, until relatively recently, were qualitative. Data-driven environmental impact measurements have traditionally been too slow or expensive to acquire. Even today, many organizations find that qualitative assessments are good enough for their purposes. Methods vary from "back of the envelope" to more rigorous, as represented by the following techniques.

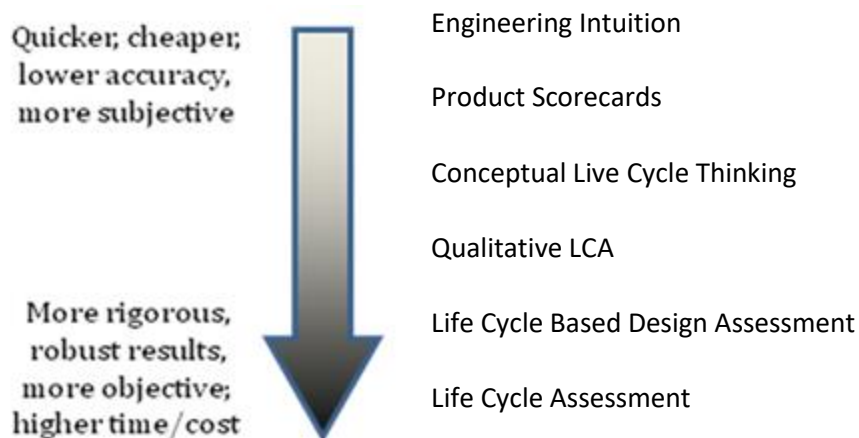

### Intuition

Most people have a broad-brush sense for the relative impacts of major design choices. For instance, intuition alone will tell you that a lighter version of a product would save on transportation costs or that a more energy-efficient product would have less of an environmental impact. Unfortunately, there are plenty of counter-intuitive trade-offs and costs unknown to the average designer.

Besides often being uninformed, many people are actually misinformed about the impacts of certain materials. Sometimes materials are attacked in the press and public opinion, painted as evil, toxic stuff. PVC has a terrible reputation, even though analysis will show that in certain applications it is the more environmentally responsible choice. In some cases, it is just because they are the most visible that certain components get the brunt of the negative attention. Transportation and packaging fall into this category, even when they might be far from the biggest problem in a given product's lifecycle.

On the flip side, there are some very significant marketing dollars at work convincing people how "green" some materials are. The cotton industry touts their product as a natural material, "The fabric of our lives." While it is true that cotton is a product of nature, its environmental impact is pretty substantial, thanks to the amount of water and insecticides used in conventional cotton farming. In fact, cotton uses approximately 25% of the world's insecticides and more than 10% of the pesticides (including herbicides, insecticides, and defoliants.). Plus, there is the ongoing issue of the increased use of genetically modified cotton. Cotton's environmental footprint has gotten much better over the years, but the "natural" option might not turn out to be the best sustainable option, despite the hype.

Intuition is fine if that's all you've got, but there are plenty of ways to do better. For example, we'll test a few of Tom and Priscilla's intuited assumptions along the way—like her assumption that manufacturing her cups locally would be better.

### **Intuition and the Three Choices**

1. Impacts – Any
2. Scope – System boundary is created by areas engineer is directly familiar with; Any life cycle stages, although usually focused on the most visible ones, such as Use
3. Metrics – Usually in the form of comments, although could be checkmarks, or scores

### **Product Scorecards**

Some companies have created scorecards to enable them to evaluate a variety of products with at least some internal consistency. Scorecards of this type are not particularly life cycle-based, but instead focus on the attributes of a product. For example, Norm Thompson Outfitters, with the help of Michael S. Brown & Associates, created a set of 12 scorecards as part of its Sustainability Toolkit, which it uses internally and gives to its suppliers and merchants. The scoring system is a simple 3 (most environmentally responsible) to -3 (least environmentally responsible), with each product element getting a single. Each score has examples and criteria listed to help people with their evaluation. For example, in the food category, a 3 indicates a sustainably harvested, organic product, free of toxics in raw material processing. A food is given a score of 0 if it's on the seafood "watch" list for instance, resulting in moderate ecosystem impacts. Foods scoring -3 would have significant negative ecosystem and human impacts. Fish on the "avoid" list would qualify, for instance. For metal products, recycled gold, silver, and copper would earn a 3, while nickel, lead, and mercury would get a -3. These scores are primarily used to guide sourcing and purchasing decisions.

Other examples of product scorecards come from companies such as Walmart, Ikea, and Liberty Global. While not a rigorous, in-depth analysis, it is a valuable tool for designers to use in considering product sustainability as they do their work.

### **Conceptual Life Cycle Thinking**

These approaches consider the life cycle of a product, but tend to have quite qualitative impact evaluations. One of the most popular tools of this type is the Lifecycle Design Strategies (or LiDS) Wheel, also known as the Ecodesign Strategies wheel. It was developed as a part of the United Nations Environment Programme by Hans Brezet and Carolien van Hemel Brezet as a way to evaluate how well a product design reflects the application of eight ecodesign strategies, especially relative to alternative

designs. These strategies are usually represented as an eight-axis radar chart, with each design option plotted as overlays, as in the figure below.<sup>23</sup>

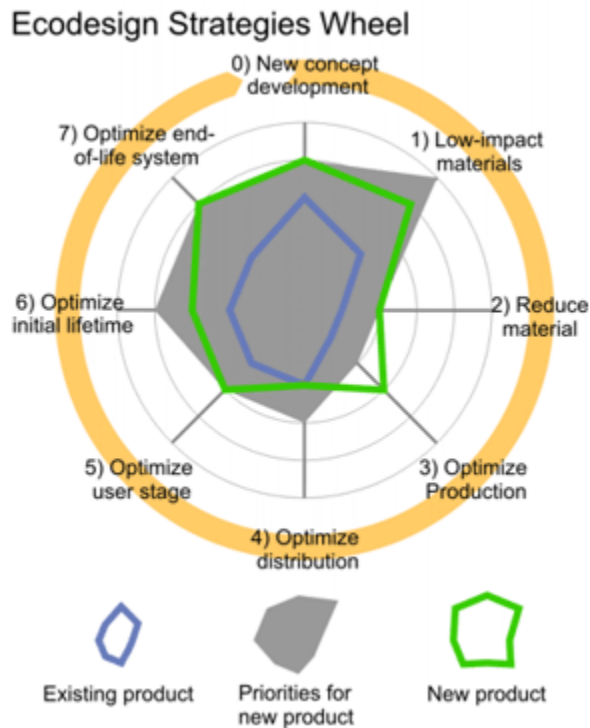

Note that there are no scales defined, plus this reflects the use of strategies, which does not necessarily translate into specific environmental impacts. As stated in the *Procedia Engineering Journal*, “Because the LiDS Wheel Analyses are inherently qualitative, and based on an arbitrarily defined system of evaluation, it is not a method that can be used to determine the actual environmental impact of a product. It is, however, an excellent method for evaluating environmental tradeoffs between two similar or evolutionary designs.”<sup>24</sup>

### Conceptual Life Cycle Thinking and the Three Choices

1. Impacts – Any, although not always broken out into specifics
2. Scope – All life cycle stages
3. Metrics – Generally scores

### Qualitative Life Cycle Assessment

Life Cycle Assessment (LCA) describes the process of evaluating the environmental impacts of a product at each stage of its life and overall. While full LCAs can be intensively data-driven, as will be described in

<sup>23</sup>

[http://wikid.io.tudelft.nl/WikID/index.php/EcoDesign\\_strategy\\_wheel#:~:text=%20The%20EcoDesign%20strategy%20wheel%20presents%20eight%20EcoDesign,lifetime%20%20Optimization%20of%20end-of-life%20system.%20More%20](http://wikid.io.tudelft.nl/WikID/index.php/EcoDesign_strategy_wheel#:~:text=%20The%20EcoDesign%20strategy%20wheel%20presents%20eight%20EcoDesign,lifetime%20%20Optimization%20of%20end-of-life%20system.%20More%20)

<sup>24</sup> Vicente Chulvi, R. V. (2011). Usefulness of evolution lines in eco-design. *Procedia Engineering*, 135-144.

<https://www.sciencedirect.com/science/article/pii/S187770581100124X>



the following section, sometimes a qualitative assessment is all that is required. This is often called a Qualitative LCA or a Qualitative Matrix LCA.

Such evaluations can be used as stand-alone decision tools, but often they serve to identify the design options worth more detailed analysis. Evaluations can be text-based or scored, but there are no standard axes or rating systems so organizations can adopt whatever metrics work for their purposes. This figure shows an example of one such matrix used by 3M.<sup>25</sup>

STAGES IMPACTS		Before Customer				Customer		
		Material Aquisition	R&D Operations	Process	Packaging	Wrhs, Distrb, Transport	Product Use, Reuse, Maintenance	Recycle, Final Disposal
		A	B	C	D	E	F	G
<b>ENVIRONMENT</b>								
Air	1							
Water	2							
Solid Waste	3							
<b>ENERGY</b>								
RESOURCE USE	4							
<b>HEALTH</b>								
Chemical	6							
Physical	7							
Biological	8							
<b>SAFETY</b>								
Chemical	9							
Electrical	10							
Mechanical	11							
<p><b>Please enter the following marks as appropriate:</b></p> <p>√ - Impacts understood and Risks adequately addressed      ? - Impacts/Risks not completely understood</p> <p>* - Impacts understood but Risks require further attention      + - EHS Advantage</p>								

Evaluation approaches become even more effective when adopted by more than one company, or even by a whole industry. One example of this is the apparel industry's Eco Index, created through the collaborative efforts of over 100 producers and retailers and coordinated by the Outdoor Industry Association.<sup>26</sup> The resulting software application guides its users through a set of questions for each of six life cycle stages, focused on seven key areas of impact.<sup>27</sup>

<sup>25</sup> Edmund E. Price, Donald R. Coy, "Life cycle management at 3M: A practical approach", Environmental Management and Health, Vol. 12 Iss: 3 (2001), pp. 254 – 259.

<sup>26</sup> <http://www.eco-index.org/new/index.cfm>

<sup>27</sup> <http://www.eco-index.org/new/index.cfm>

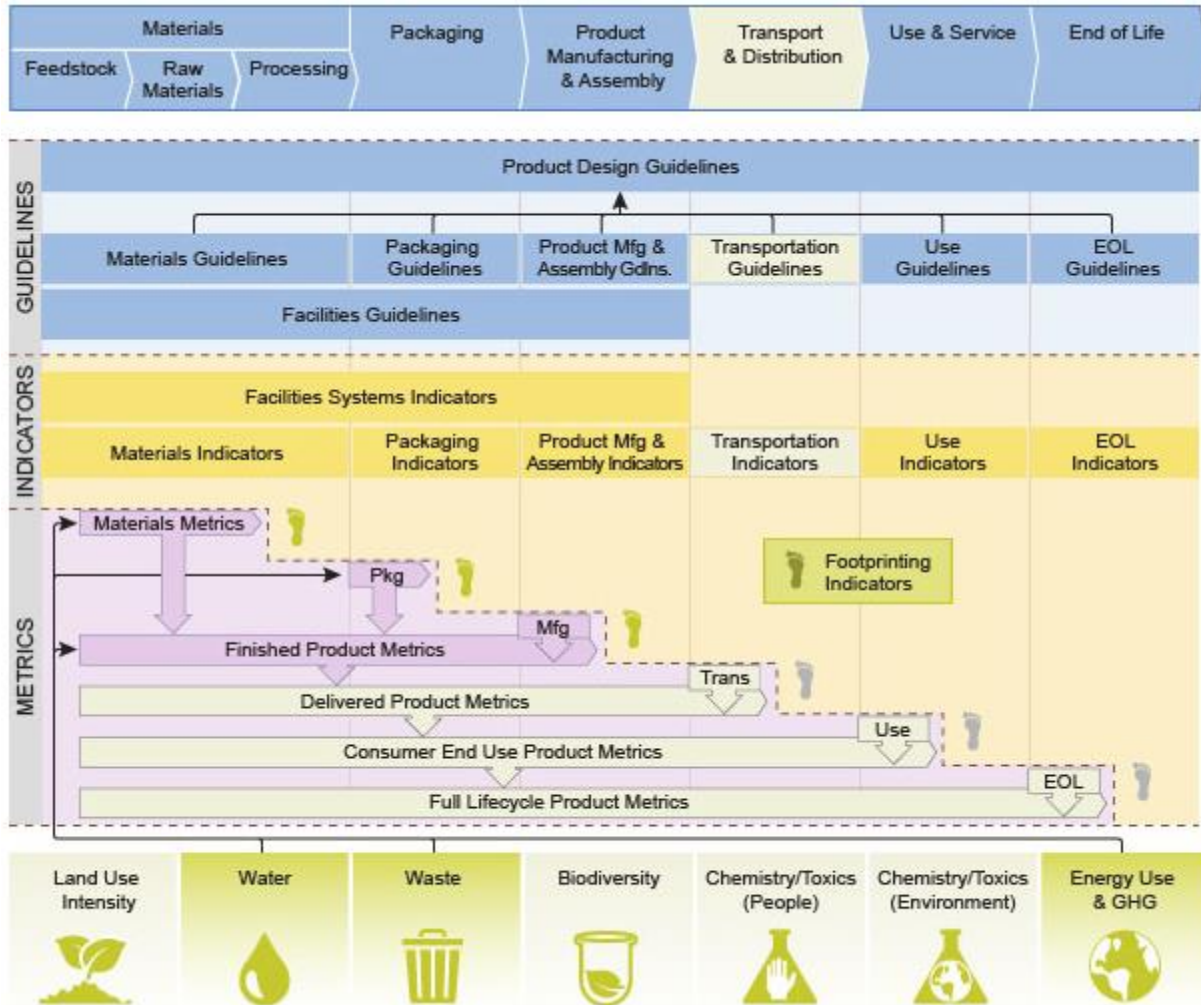

The scoring system is based on points awarded based on meeting various criteria. For example, in the Packaging area, Post-Consumer Recycled (PCR) Content scores range from 0 for “unknown or 0-29% post-consumer recycled content” to a maximum of 8 for 100% PCR content. Such scoring systems try to reflect the scale of impact somewhat quantitatively, although the direct impact of changes is hard to see. The scorecard’s guidelines state that use of PCR leads to resource conservation such as less energy used, less waste produced, and less virgin raw material extracted, but does not say how much. Therefore, it is not easy to tell whether it makes a big or small difference changing from, say, 29% PCR to 30% PCR to get an extra point on the scorecard, something product designers may want to know. Plus, a one point change due to PCR use may have very different environmental impacts than a one point change in raw material input use efficiency. Results are in the form of points, not impacts.

Qualitative impact assessments tend to be quicker, less expensive, and easier for non-specialists to participate in and understand than quantitative ones. Their lack of precision can be acceptable for many high-level decisions, or for indicating when it is worth investing the time and effort required to generate a more detailed understanding of the environmental impacts that many quantitative methods can provide.

### Qualitative LCA and the Three Choices

1. Impacts – Any
2. Scope – All life cycle stages
3. Metrics – Generally scores

### Life Cycle-Based Design Assessment

There is an impact evaluation approach that reflects life cycle thinking but is more quantitatively rigorous in its metrics than the tools and techniques described above, and yet is still useful for evaluating products still in the design phase. Life cycle based design assessments reflect many of the attributes of full life cycle assessments, but are based on product models and not on full studies of a product's actual environmental impacts. Because they usually draw upon one or more existing impact data sets, they have the advantage of being useful in making data-driven design decisions while still at the drawing board. Most are software applications, allowing fast data search and impact calculations.

#### Industry-specific

Some approaches of this type are focused on particular industries or applications. The Comparative Packaging Assessment (COMPASS)<sup>28</sup> is an online tool developed by the Sustainable Packaging Coalition (SPC), a project of the nonprofit institute GreenBlue. Drawing upon life cycle impact data from the U.S. Life-Cycle Inventory (LCI) Database and Ecoinvent (a Swiss LCI database), it allows engineers and packaging designers to model the impacts of their choices while still in the design phase. It calculates profiles of product life cycle impacts in three main categories.

#### Consumption Metrics

- Fossil Fuel
- Water
- Biotic Resource
- Mineral

#### Emission Metrics

- Greenhouse Gas
- Clean Production: Human Impacts
- Clean Production: Aquatic Toxicity
- Eutrophication

#### Packaging Attributes

- Content (Recycled or Virgin)
- Sourcing
- Solid Waste
- Material Health

#### Industry-agnostic

Other tools, such as SOLIDWORKS Sustainability, don't focus on one particular design domain, but allow modeling of a wide range of products. SOLIDWORKS has chosen its approach specifically to meet the

---

<sup>28</sup> <https://greenblue.org/work/compass/>

needs of designers and engineers who want to incorporate pre-production modeling of environmental impacts into their product development process.

Like other tools of this type, SOLIDWORKS Sustainability uses secondary LCA data to develop a quick, robust assessment, which could be called a “screening LCA” or an LCA-based design assessment. But because it doesn’t use the company’s own primary data, SOLIDWORKS Sustainability shouldn’t replace comprehensive LCA software, such as Sphera’s GaBi software.

SOLIDWORKS Sustainability should be used as an environmental impact dashboard, giving immediate feedback on the impact of design decisions. Although it may be considered LCA “light,” it is powered by Sphera’s LCA database (confusingly also called GaBi), and uses a general process model made using the GaBi LCA software. This powerful engine provides designers with the tools appropriate for creating comparative models and making educated trade-off decisions. Its integration with SOLIDWORKS’ 3D modeling suite enables real-time impact analysis during the design process.

In SOLIDWORKS Sustainability, impacts are represented in several categories. It assumes that designers benefit from more granularity than a single number score can give, but that environmental impacts can easily be understood and estimated by using a small set of key environmental indicators. It currently shows four types of environmental impacts:

- Natural resource depletion: **Non-Renewable Lifecycle Energy Demand**
- Impact to the air: **Air Acidification**
- Impact to water/earth: **Water Eutrophication**
- Impact to the climate: **Carbon Footprint**

SOLIDWORKS Sustainability has been developed to enable sustainable design in the context of product design, helping developers make informed choices about environmental impacts early enough in their life cycles to lock in benefits from the start. With tools of this type, environmental impact becomes a design decision and not a post mortem examination.

### Life Cycle Assessment

Several of the other methods described so far have addressed each of the components of a product's life cycle. There is however a specific process called Life Cycle Assessment (LCA) with a standardized set of steps and output in the form of environmental impact measures. In fact, life cycle assessment is part of the ISO 14000 (environmental management) standards, and is specifically addressed by ISO 14040:2006 and 14044:2006.

LCA is defined as "an objective process to evaluate the environmental burdens associated with a product, process, or activity by identifying energy and materials used and wastes released to the environment, and to evaluate and implement opportunities to affect environmental improvements."<sup>29</sup> Performing a full LCA requires significant expertise and effort. There are many resources available that go into much more detail about the process than this guide covers.<sup>30</sup> However, it is useful to at least be familiar with the four major steps of the standardized LCA process:

---

<sup>29</sup> Society of Environmental Toxicology and Chemistry (SETAC), 1990

<sup>30</sup> See for instance "Life Cycle Assessment: Principles and Practice," Scientific Applications International Corporation, EPA/600/R-06/060 (May 2006)

1. Goal and Scope Definition – What are we trying to learn?
2. Life Cycle Inventory (LCI) – What's embedded in the product?
3. Life Cycle Impact Assessment (LCIA) – What effects does it have?
4. Data Interpretation – What does it all mean?

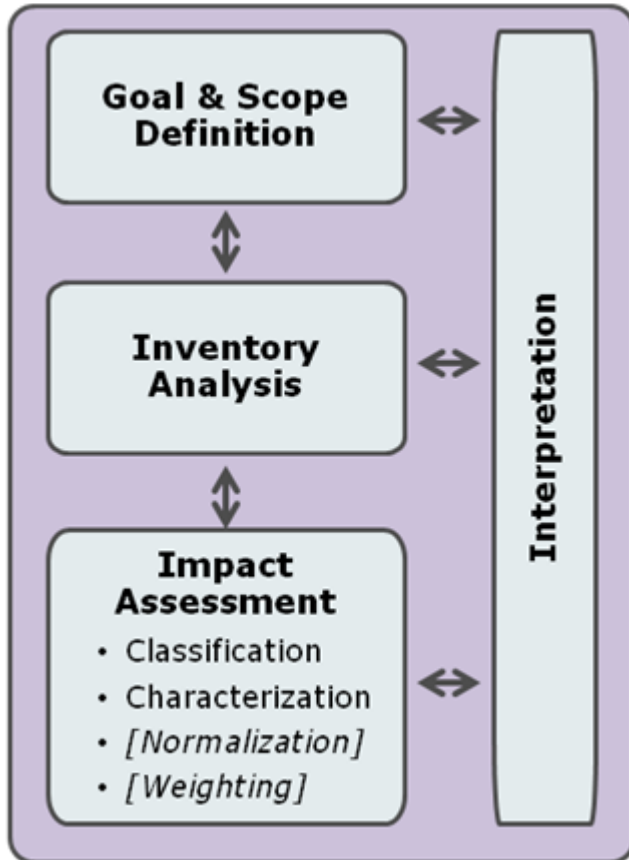

### Goal & Scope Definition

As with other assessments, the first step involves clarifying the purpose and extent of the LCA. This entails formally determining the functional unit, impacts of interest, and system boundary—elements from our "First Choice".

While LCA "light" approaches have been described above, a "full" LCA includes actual primary environmental impact data gathered once the product's full lifecycle has been determined. Such

detailed LCAs take, on average, three months<sup>31</sup>, and are only possible to complete once the product is in use and has gone through all stages of its life cycle. This increased accuracy is worth it for benchmarking or external reporting (such as green marketing) purposes.

### Inventory Analysis

The next phase entails creating a list of all of the components of the products life cycle that fall within the defined system boundary. It has three major steps:

1. Construct a process flowchart that shows the following:
  - Raw materials
  - Mfg processes
  - Transports
  - Uses
  - Waste management
2. Collect data for:
  - Material inputs
  - Products and byproducts
  - Solid waste, air and water emissions
3. Calculate the amounts of each in relation to the functional unit

Essentially, this is the process flow diagram—with detailed mass and energy values attached—that Tom and Priscilla sketched out. The resulting Life Cycle Inventory (LCI) provides a breakdown of all of the energy and materials involved in a product's system at a level of detail that provides a basis for evaluation.

### Impact Assessment

Once a detailed LCI is created, environmental impacts can be ascribed to its parts, and if desired to the whole system. There are four steps to the Life Cycle Impact Assessment (LCIA) process, the first two of which are considered mandatory, while the last two are optional.<sup>32</sup>

#### 1. Classification

Classification involves assigning specific environmental impacts to each component of the LCI. It is here where decisions made during the scope and goal phase about what environmental impact categories are of interest come into play.

#### 2. Characterization

Once the impact categories have been identified, conversion factors – generally known as characterization or equivalency factors – use formulas to convert the LCI results into directly comparable impact indicators as described in the Measurements section above.

#### 3. Normalization (optional)

---

<sup>31</sup> "A full (internal) LCA study takes 8-16 weeks to complete." <http://www.industrial-ecology.com/services/lifecycleassessment.html>

<sup>32</sup> As dictated by the ISO 14044 standard

Some practitioners choose to normalize the impact assessment by scaling the data by a reference factor, such as the region's per capita environmental burden. This helps to clarify the relative impact of a substance in a given context. For instance, if global warming contributions are already high in the context in which the product is being assessed, a reference factor would normalize whatever the product's global warming contributions are in order to clarify its relative impacts.

#### 4. Weighting (optional)

The pros and cons of weighting were described in the Measurements section above.

#### Interpretation

Although listed fourth, life cycle interpretation actually occurs throughout the whole LCA. It involves the ongoing process of clarifying, quantifying, checking, and evaluating the information used by, and resulting from, the life cycle inventory (LCI) and impact assessment (LCIA) phases. The standard that covers the LCA process, ISO 14044, gives two main objectives:

1. Analyze results, reach conclusions, explain limitations, and provide recommendations based on the findings of the preceding phases of the LCA, and to report the results of the life cycle interpretation in a transparent manner.
2. Provide a readily understandable, complete, and consistent presentation of the results of an LCA study, in accordance with the goal and scope of the study.

To achieve these objectives, the ISO standard states that interpretation should cover at least three major elements.

1. Identification of the significant issues based on the LCI and LCIA. Which life cycle stages or components stand out as major contributors to overall impact? What are the anomalies?
2. Evaluation which considers completeness, sensitivity, and consistency checks. Is all the information needed for interpretation present in the LCI and LCIA? How reliable is the information related to any identified significant issues? How much do changes in such factors influence the overall results? Are all of the assumptions, data, characterization factors, etc. that were used in the assessment consistent internally and with the overall goal and scope of the LCA?
3. Conclusions, recommendations, and reporting. As discussed in later sections of this guide, a great deal of an LCA's value depends on how its results are communicated to people involved in making relevant decisions, whether other designers, engineers, management, marketers, or other parts of the supply chain.

It is very important to note that no matter how carefully assembled, analyzed, assessed, and measured, LCAs are never the "real" answer. They require interpretation, which in turn requires transparency and judgment. The data sources, assumptions, and all other relevant information needs to be transparent to decision makers so that they can understand the full context of the results of the life cycle inventory assessment. Deciding among design options is not as easy as just comparing LCIA numbers, whether single- or multi-factor, weighted or not. LCIA results can be a source of insights, but do not stand alone in guiding product development choices. Engineers will need to take them in the context of the other attributes they are trying to optimize, including cost, manufacturability, performance, and so on. In

addition, there are myriad other factors guiding product development decisions not covered by LCAs, including social impacts and acceptance, pricing, political agendas, and regulations.

**LCA and the Three Choices**

1. Impacts – Any
2. Scope – All life cycle stages
3. Metrics – Measurements from actual product life cycle, supported by data tables

*"Whew, I never knew environmental assessment was such a complex world!" breathed Tom.*

*"Well, we've already decided that we wanted to use measurements for our Third Choice, the one on metrics. If only there were a handy table to show us what Tools were available to us now, given our three choices."*

A Handy Table of Tools for the Three Choices

	<b>Choice 1: Impacts</b>	<b>Choice 2: Scope</b>	<b>Choice 3: Metrics</b>
<b>Intuition</b>	Any	Visible stages	Comments, checkmarks, scores
<b>Product Scorecards</b>	Any	Set boundary, usually product mfg and assembly	Checkmarks, scores
<b>Conceptual Life Cycle Thinking</b>	Any (but usually not specific)	All lifecycle stages	Scores
<b>Qualitative LCA</b>	Any	All lifecycle stages	Scores
<b>Life Cycle-Based Design Assessment</b>	Any	All lifecycle stages	Measurements (secondary data)
<b>Life Cycle Assessment (LCA)</b>	Any	All lifecycle stages	Measurements (primary data)

*"It looks like what I need is a Life Cycle-Based Design Assessment," said Priscilla. "Since I already have my model in SOLIDWORKS, it makes sense for me to use Sustainability."*

*"I do too," said Tom. "So I'll start out in SOLIDWORKS Sustainability too. But if I want to use my results in marketing, I'll eventually need to do an LCA to verify the results."*

**Chapter 5: So What? (Interpreting the Results)**

The previous sections have laid out the context of sustainability and described how to know it when you see it. However, all of that information is irrelevant if it doesn't enable action—the point of assessing



and reporting environmental impacts is to give you information on how design choices affect the relative sustainability of one product compared with other options. This section and the ones that follow show how to put all of that information into action.

The first step is to determine what the results of the environmental impact assessments mean. No matter which tools or techniques you used, you should have some impact information about your product. As was noted earlier, sustainable design is a relative concept, so you should also have impact information against which to compare it. Common comparisons include:

**Standards:** These may be certain thresholds or impact profiles that have been accepted as industry, or maybe even just company, standards.

**Previous Designs:** The goal may be to make each generation of a product more sustainable than the previous one.

**Competitive Products:** Whether for market positioning or internal purposes, it is sometimes helpful to compare to other companies' solutions.

**Alternative Designs:** One of the most common is to compare variations on a given design to each other to narrow down development to the best, most sustainable design options.

The comparison set should have been identified early in the process so that relevant impact information about the alternative designs could be gathered as a part of the overall process.

As you conduct the comparisons, it's important to know what differences are meaningful. The significance of any differences identified will depend on the products and the measurement approach used. For even the more data-driven techniques used, not all incremental improvements are worth investigating. As a simple rule of thumb:

A +/- 10% difference on one or several environmental indicators gives an indication that the changes between the options can be considered "directionally" correct. Chances are, you're moving on the right path.

For a relatively simple product—like Priscilla's cup—a difference of +/- 30% on the indicator(s) is generally a meaningfully greener product.

For a more complex product, the decrease in impact that you should look to see to identify a greener product are higher, perhaps +/- 40-50%, because the chances of overlooking process steps or incorrectly modeling some assumptions increase with the complexity of the product.

These may seem like large percentages, but they can serve as a helpful reminder not to get caught up in trying to tweak less relevant aspects of a product and instead to focus on the major contributors to its impacts. This is particularly true given the need for the designer to simultaneously balance the environmental impacts of a product with its cost, durability, and other design criteria, along with how it fits in with the overall product strategy.

*"Wow, that's not as accurate as I thought given all of the calculations behind our LCA data," said Tom reflectively.*

*“Actually, I think it’s pretty accurate,” responded Priscilla. “Keep in mind that measuring a single product’s impact on a global environmental metric like climate change is like trying to predict the weather in Boston a thousand years from today.”*

*Once you have a sense for which impact areas are worth looking at, whether because of the significance of their differences from alternatives or other reasons (e.g., a corporate focus on carbon footprint), it is time to look for ways to reduce those impacts as effectively as possible. In many cases, there are certain elements of the design or product life cycle that generate most of the impact. It’s often a classic example of the 80/20 rule, with 20% of the design contributing 80% of the impact. For instance, in decreasing the impact of an electric coffeemaker the temptation might be to remold the plastic housing, since plastic is generally considered a less-than-sustainable material. However, simply shortening the electric cord decreases its overall impact many times what is saved by replacing the handle; and decreasing its energy usage may even dwarf that impact.*

*“Alright, enough preparation, Tom! I think we know enough now to responsibly dig into our products. Can I go first?”*

## Chapter 6: A Redesigned Cup, A Reconsidered Toy

Priscilla's Challenge: Redesigning a plastic cup (SustainabilityXpress & Sustainability)

Tom's Turn: Reconsidering a children's toy (Sustainability only)

### Priscilla’s Challenge

Download the model to play along with this example

([https://files.solidworks.com/sustainability/Guide\\_cup\\_files.zip](https://files.solidworks.com/sustainability/Guide_cup_files.zip)).

*“Let's start by opening up SustainabilityXpress in the part model,” said Priscilla. “I don't have full Sustainability, but I should be able to do what I need to do for my part.” Tom looked over Priscilla's shoulder as she fired up SustainabilityXpress.*

*“Alright, I see a list of drop-down options to input some basic design parameters so that it can calculate my impacts. First, I'll make sure the materials are set correctly.”*

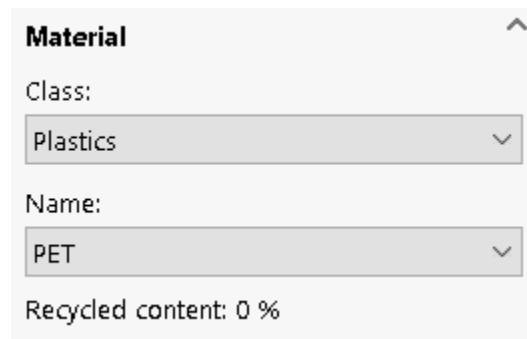

The screenshot shows a 'Material' selection panel. It has a title 'Material' with an upward-pointing arrow. Below the title are two dropdown menus. The first is labeled 'Class:' and has 'Plastics' selected. The second is labeled 'Name:' and has 'PET' selected. Below the dropdowns, it says 'Recycled content: 0 %'.

*“Yep, there's the PET. Looks like it's a pretty light part. And there's the 'Find Similar' tool, I definitely want to check that one out.*

*"Next it's asking me about the manufacturing process for the part. Let's see," said Priscilla as she glanced at her process flow diagram sketch, "it's Injection Molded in Asia, and let's look at the scenario of using it in the North American markets."*

**Manufacturing** ^

Region:  
Asia v



Built to last:  
1.00 [up/down] Year v

Process:  
Injection Molded v

- ⚠ 0.84 kWh
- 💧 0.00 BTU
- 🗑 2.00 %

**Use** ^

Region:  
North America v





*"How does it get from Asia to North America?" asked Tom.*

*"Well, it goes by boat, but it looks like there's no option to set the transport mode in my version... but I think there's some defaults posted on what it uses." Priscilla checked out the SustainabilityXpress Default Distances and confirmed that it assumes her stacks of cups are shipped from ports in Asia to North America.*

*"And wow, that's all I need. SustainabilityXpress is now giving me some estimates of the environmental impact.*

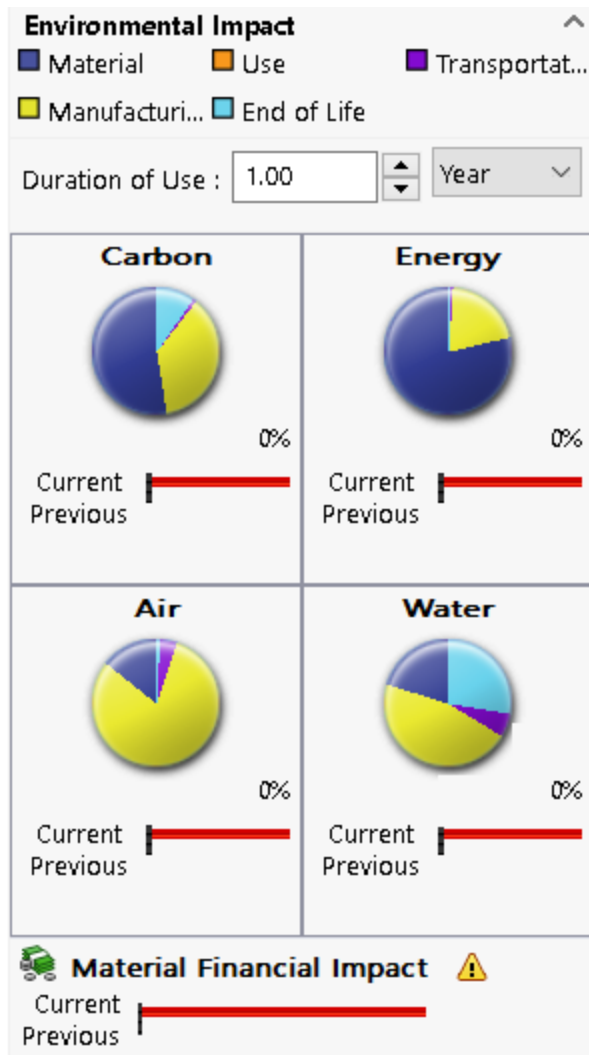

*See, it has four of the five domains that I wanted to measure. It estimates that a single cup is responsible for:*

- *0.09 kg-eq CO<sub>2</sub>, or 90 grams of carbon-equivalent greenhouse gases;*
- *1.6 MJ of non-renewable energy consumed throughout the lifecycle (wow, that's a lot for a little cup!);*
- *5.8e-4 kg-eq SO<sub>2</sub> of Air Acidification; and*
- *3.9e-5 kg-eq PO<sub>4</sub> of Water Eutrophication.*

*"Well, about the only measurement that means anything to me in the absolute sense is the energy demand. I guess I'll set this as the baseline so I can play with some different designs and see how they compare."*

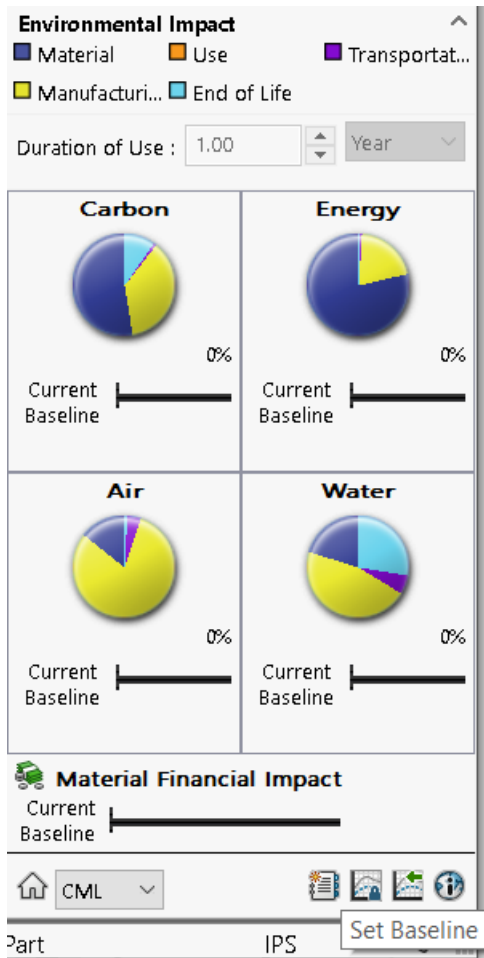

After setting the baseline, Priscilla saved the model (with the Sustainability options set), and did a Save As to play with some new redesign parameters in a clean file.

*"Now for the redesign. I want to start by doing the obvious thing and seeing the effects of manufacturing this locally, in North America where it's being used." Priscilla changed the manufacturing location from Asia to North America, and her eyes opened wide at the result:*

**Manufacturing** ^ ^









Region:  
 North America v



**Environmental Impact** ^

Material  
  Use  
  Transportat...  
 Manufacturi...  
 End of Life

Duration of Use : 1.00  
 Year v

<p><b>Carbon</b></p>  <p>↑ 2%</p> <p>Current Baseline</p> 	<p><b>Energy</b></p>  <p>↑ 8%</p> <p>Current Baseline</p> 
<p><b>Air</b></p>  <p>↓ -44%</p> <p>Current Baseline</p> 	<p><b>Water</b></p>  <p>↓ -21%</p> <p>Current Baseline</p> 

**Material Financial Impact**

Current Baseline



CML v  

*"What?! It's actually not clearly better to manufacture locally! It appears to be better for air and water impacts, but since I'm trying to optimize on all four impacts, I have to reconsider since it's worse on*

carbon and energy demand. I guess that's because trucking my cups around within North America has greater impacts per mile than shipping all the way from Asia."

"How about trying to change the material you're using instead?" offered Tom. Priscilla nodded and changed the options back to manufacturing in Asia. She then clicked the "Find Similar" tool, and was presented by the following dialog box.

The screenshot shows the 'Find Similar Material' dialog box. At the top, there is a table with columns: Materials, Material Class, N/m<sup>2</sup>, N/A, kg/m<sup>3</sup>, W/(m·K), J/(kg·K), N/m<sup>2</sup>, and N/m<sup>2</sup>. The row for PET shows values: 2.96e+09, 0.37, 1420, 0.261, 1140, 5.73e+07, and 9.29e+07.

Below the table is a search criteria table with columns: Property, Condition, Value, and Units. The criteria are:

Property	Condition	Value	Units
Material Class	=	-any-	
	-any-	2.96e+09	N/m <sup>2</sup>
	-any-	0.37	N/A
	-any-	1420	kg/m <sup>3</sup>
	-any-	0.261	W/(m·K)
	-any-	1140	J/(kg·K)
	-any-	5.73e+07	N/m <sup>2</sup>
	-any-	9.29e+07	N/m <sup>2</sup>
Financial Impact	-any-	2.20	USD/kg

On the right side of the dialog, there is a text box that says: "Select search criteria. Set the condition(s) and value(s)". Below this is a "Find Similar" button.

At the bottom of the dialog, there is a section titled "Environmental Impact" with four pie charts comparing "Selected" and "Original" materials. Below the charts is a "Material Financial Impact" section with a bar chart comparing "Selected" and "Original" materials. On the right side of this section, there are dropdown menus for "Manufacturing Process" (set to "Injection Molded") and "Units" (set to "SI - N/m<sup>2</sup> (Pa)"). At the bottom right of this section are buttons for "Accept", "Edit", "Cancel", and "Help".

"OK, these are the engineering properties of my PET material, and I can see the baseline impacts of my part down below. It's asking me to narrow down my engineering requirements so that it can suggest alternate materials.

Let's see. I don't want to leave the class of plastics, because that's what I'm comfortable working with. I want to try a polymer that's lighter than PET so that I can reduce the weight for transport, but I need a certain minimal strength so that it doesn't break in packing and shipping." Priscilla narrowed the options to reflect these requirements:



Find Similar Material

Materials	Material Class	N/m <sup>2</sup>	N/A	kg/m <sup>3</sup>	W/(m·K)	J/(kg·K)	N/m <sup>2</sup>	N/m <sup>2</sup>
PET	Plastics	2.96e+09	0.37	1420	0.261	1140	5.73e+07	9.29e+07

Property	Condition	Value	Units
Material Class	=	-any-	
	-any-	2.96e+09	N/m <sup>2</sup>
	-any-	0.37	N/A
	-any-	1420	kg/m <sup>3</sup>
	-any-	0.261	W/(m·K)
	-any-	1140	J/(kg·K)
>	-any-	2e+07	N/m <sup>2</sup>
	-any-	9.29e+07	N/m <sup>2</sup>
	-any-	2.20	USD/kg

Select search criteria. Set the condition(s) and value(s)

Find Similar

---

Environmental Impact



Material Financial Impact

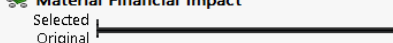

Manufacturing Process: Injection Molded

Units: SI - N/m<sup>2</sup> (Pa)

Accept Edit Cancel Help

*"And now let's click 'Find Similar' and see what it suggests!"*

Find Similar Material

Materials	Material Class	N/m <sup>2</sup>	N/A	kg/m <sup>3</sup>	W/(m·K)	J/(kg·K)	N/m <sup>2</sup>	N/m <sup>2</sup>
<input type="checkbox"/> PET	Plastics	2.96e+09	0.37	1420	0.261	1140	5.73e+07	9.29e+07
<input type="checkbox"/> 1023 Carbon Steel Shee...	Steel	2.05e+11	0.29	7858	52	486	4.25e+08	
<input type="checkbox"/> 201 Annealed Stainless ...	Steel	2.07e+11	0.27	7860	16.3	502	6.85e+08	
<input type="checkbox"/> A286 Iron Base Superall...	Steel	2.01e+11	0.31	7920	15.1	420	6.2e+08	
<input type="checkbox"/> AISI 1010 Steel, hot rolle...	Steel	2e+11	0.29	7870	51.9	448	3.25e+08	
<input type="checkbox"/> AISI 1015 Steel, Cold Dr...	Steel	2.05e+11	0.29	7870	52	486	3.85e+08	
<input type="checkbox"/> AISI 1020	Steel	2e+11	0.29	7900	47	420	4.20507e+08	
<input type="checkbox"/> AISI 1020 Steel, Cold Rol...	Steel	2.05e+11	0.29	7870	51.9	486	4.2e+08	
<input type="checkbox"/> AISI 1035 Steel (SS)	Steel	2.05e+11	0.29	7850	52	486	5.85e+08	
<input type="checkbox"/> AISI 1045 Steel, cold dra...	Steel	2.05e+11	0.29	7850	49.8	486	6.25e+08	
<input type="checkbox"/> AISI 304	Steel	1.9e+11	0.29	8000	16	500	5.17017e+08	
<input type="checkbox"/> AISI 316 Annealed Stainl...	Steel	1.93e+11	0.3	8000	16.3	500	5.5e+08	
<input type="checkbox"/> AISI 316 Stainless Steel ...	Steel	1.93e+11	0.27	8000	16.3	500	5.8e+08	
<input type="checkbox"/> AISI 321 Annealed Stainl...	Steel	1.93e+11	0.27	8000	16.1	500	6.2e+08	
<input type="checkbox"/> AISI 347 Annealed Stainl...	Steel	1.95e+11	0.27	8000	16.3	500	6.55e+08	
<input type="checkbox"/> AISI 4130 Steel, anneal...	Steel	2.05e+11	0.285	7850	42.7	477	5.6e+08	
<input type="checkbox"/> AISI 4130 Steel, normaliz...	Steel	2.05e+11	0.285	7850	42.7	477	7.31e+08	
<input type="checkbox"/> AISI 4340 Steel, annealed	Steel	2.05e+11	0.285	7850	44.5	475	7.45e+08	
<input type="checkbox"/> AISI 4340 Steel, normaliz...	Steel	2.05e+11	0.32	7850	44.5	475	1.11e+09	
<input type="checkbox"/> AISI Type 316L stainless ...	Steel	2e+11	0.265	8027	14.6	450	4.85e+08	
<input type="checkbox"/> Alloy Steel	Steel	2.1e+11	0.28	7700	50	460	7.238256e+08	
<input type="checkbox"/> Alloy Steel (SS)	Steel	2.1e+11	0.28	7700	50	460	7.238256e+08	
<input type="checkbox"/> ASTM A36 Steel	Steel	2e+11	0.26	7850			4e+08	
<input type="checkbox"/> Cast Alloy Steel	Steel	1.9e+11	0.26	7300	38	440	4.480825e+08	
<input type="checkbox"/> Cast Carbon Steel	Steel	2e+11	0.32	7800	30	500	4.82549e+08	
<input type="checkbox"/> Chrome Stainless Steel	Steel	2e+11	0.28	7800	18	460	4.13613e+08	
<input type="checkbox"/> Galvanized Steel	Steel	2e+11	0.29	7870			3.569007e+08	
<input type="checkbox"/> Plain Carbon Steel	Steel	2.1e+11	0.28	7800	43	440	3.99826e+08	
<input type="checkbox"/> Stainless Steel (ferritic)	Steel	2e+11	0.28	7800	18	460	5.13613e+08	
<input type="checkbox"/> Wrought Stainless Steel	Steel	2e+11	0.26	8000	19	500	5.17017e+08	
<input type="checkbox"/> Ductile Iron	Iron	1.2e+11	0.31	7100	75	450	8.61695e+08	
<input type="checkbox"/> Ductile Iron (SN)	Iron	1.2e+11	0.31	7100	75	450	8.61695e+08	
<input type="checkbox"/> Gray Cast Iron	Iron	6.61781e+10	0.27	7200	45	510	1.51658e+08	5.72165e+C

Environmental Impact

Selected Original

Selected Original

Selected Original

Selected Original

Material Financial Impact

Selected Original

Manufacturing Process

Injection Molded

Units

SI - N/m<sup>2</sup> (Pa)

Accept Edit Cancel Help

*"Oh my gosh, that's quite a list. I can toss a few of these because they're too expensive, some because I just have no experience working with them, and some because they're just plain silly for a cup." Priscilla clicked the checkboxes to the left of the materials she wanted to keep, and then clicked the icon left of the "Materials" heading to sort the list.*

Find Similar Material

Materials	Material Class	N/m <sup>2</sup>	N/A	kg/m <sup>3</sup>	W/(m·K)	J/(kg·K)	N/m <sup>2</sup>	N/m <sup>2</sup>	
<input type="checkbox"/>	PET	Plastics	2.96e+09	0.37	1420	0.261	1140	5.73e+07	9.29e+07
<input checked="" type="checkbox"/>	ABS		2e+09	0.394	1020	0.2256	1386	3e+07	
<input checked="" type="checkbox"/>	ABS PC		2.41e+09	0.3897	1070	0.2618	1900	4e+07	
<input checked="" type="checkbox"/>	Acrylic (Medium-high im...		3e+09	0.35	1200	0.21	1500	7.3e+07	
<input checked="" type="checkbox"/>	PC High Viscosity		2.32e+09	0.3912	1190	0.189	1535	6.27e+07	
<input checked="" type="checkbox"/>	PE High Density		1.07e+09	0.4101	952	0.461	1796	2.21e+07	
<input checked="" type="checkbox"/>	PP Copolymer		8.96e+08	0.4103	890	0.147	1881	2.76e+07	
<input checked="" type="checkbox"/>	PP Homopolymer		1.79e+09		933	0.117		3.3e+07	3.93e+07
<input checked="" type="checkbox"/>	PS HI		2.1e+09		1080	0.251		2.4e+07	

Environmental Impact

Manufacturing Process: Injection Molded

Units: SI - N/m<sup>2</sup> (Pa)

Material Financial Impact

Accept Edit Cancel Help

*She then clicked on the first material to see its comparative impact. "Oh boy, ABS is a lot worse than the PET on all four indicators." She continued down the materials, and began to worry that she wouldn't find a more sustainable material. She got down to polypropylene homopolymer, and rejoiced upon seeing green bars on all four indicators:*

Find Similar Material

Materials	Material Class	N/m <sup>2</sup>	N/A	kg/m <sup>3</sup>	W/(m·K)	J/(kg·K)	N/m <sup>2</sup>	N/m <sup>2</sup>
<input checked="" type="checkbox"/> PET	Plastics	2.96e+09	0.37	1420	0.261	1140	5.73e+07	9.29e+07
<input checked="" type="checkbox"/> ABS		2e+09	0.394	1020	0.2256	1386	3e+07	
<input checked="" type="checkbox"/> ABS PC		2.41e+09	0.3897	1070	0.2618	1900	4e+07	
<input checked="" type="checkbox"/> Acrylic (Medium-high im...		3e+09	0.35	1200	0.21	1500	7.3e+07	
<input checked="" type="checkbox"/> PC High Viscosity		2.32e+09	0.3912	1190	0.189	1535	6.27e+07	
<input checked="" type="checkbox"/> PE High Density		1.07e+09	0.4101	952	0.461	1796	2.21e+07	
<input checked="" type="checkbox"/> PP Copolymer		8.96e+08	0.4103	890	0.147	1881	2.76e+07	
<input checked="" type="checkbox"/> PP Homopolymer		1.79e+09		933	0.117		3.3e+07	3.93e+07
<input checked="" type="checkbox"/> PS HI		2.1e+09		1080	0.251		2.4e+07	

Environmental Impact

Manufacturing Process: Injection Molded  
Units: SI - N/m<sup>2</sup> (Pa)

Material Financial Impact: Selected Original -21%

Buttons: Accept, Edit, Cancel, Help

*"That's great!" she said, but then she thought about the other engineering properties. "Oh man, I'd really like to use something that has similar insulating properties as PET, and the conductivity of PP is pretty different," she said to Tom. "But the last remaining choice is High-Impact Polystyrene, and everyone knows how bad that is. Polystyrene is what they make Styrofoam from, after all."*

*"Try it anyway," said Tom. "It has a similar conductivity to your PET."*

*Without expecting much, Priscilla clicked on the "PS HI" material and was surprised to find:*

Materials	Material Class	N/m <sup>2</sup>	N/A	kg/m <sup>3</sup>	W/(m·K)	J/(kg·K)	N/m <sup>2</sup>	N/m <sup>2</sup>	
<input type="checkbox"/>	PET	Plastics	2.96e+09	0.37	1420	0.261	1140	5.73e+07	9.29e+07
<input checked="" type="checkbox"/>	ABS		2e+09	0.394	1020	0.2256	1386	3e+07	
<input checked="" type="checkbox"/>	ABS PC		2.41e+09	0.3897	1070	0.2618	1900	4e+07	
<input checked="" type="checkbox"/>	Acrylic (Medium-high im...		3e+09	0.35	1200	0.21	1500	7.3e+07	
<input checked="" type="checkbox"/>	PC High Viscosity		2.32e+09	0.3912	1190	0.189	1535	6.27e+07	
<input checked="" type="checkbox"/>	PE High Density		1.07e+09	0.4101	952	0.461	1796	2.21e+07	
<input checked="" type="checkbox"/>	PP Copolymer		8.96e+08	0.4103	890	0.147	1881	2.76e+07	
<input checked="" type="checkbox"/>	PP Homopolymer		1.79e+09		933	0.117		3.3e+07	3.93e+07
<input checked="" type="checkbox"/>	PS HI		2.1e+09		1080	0.251		2.4e+07	

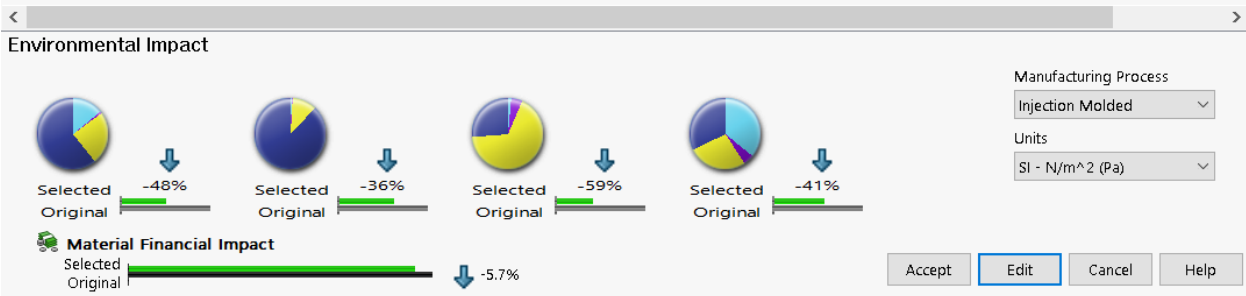

*"Green bars!!" Priscilla proclaimed. "HIPS is a greener material on all four indicators, compared to PET. Who would have thought it!"*

*"Careful," said Tom, "you know there's no such thing as a miracle material. Still, in this application, it looks like HIPS is the best material you can use."*

*Priscilla clicked Accept, and then clicked the Set Material button in the Sustainability pane to set her part to High-Impact Polystyrene.*

**Material**

Class:

Name:

Recycled content: 0 %

*"Sustainability isn't just about the material choice," said Tom. "Is there something you can do to redesign the geometry of the cup to use less material?"*

*Priscilla thought about that. "Hmm, let's see. I could make the cup really tall and skinny, or wide and squat; I wonder what that does to the environmental impact?" She reset the Baseline by clicking once to release it, and again to set it to the new material.*

Priscilla, being a relative SOLIDWORKS novice, figured that the easiest way for her to model the volume was in a separate part. She opened a new SOLIDWORKS document, made a quick sketch with the rough shape and dimensions of the cup, and revolved it as a solid. A quick check of the Mass Properties told her the volume of the cup, and she could play with the dimensions of the solid through trial and error to match the volume of her cup.

*"Let me try making the cup extremely tall and skinny, or really wide and short." She figured out the dimensions to match the volume, and then edited the sketch in her Cup model to have a bottom radius of 0.50, a top radius of 0.75, and a height of 30 inches. After they both laughed, Priscilla excited the sketch and checked the Sustainability dashboard—all the gains from changing material would be lost, as she was actually above the original PET baseline, now at 0.11 kg-eq CO<sub>2</sub> and 2.20 MJ energy, with similar increases in air and water effects.*

*Next, Priscilla tried the opposite—she changed the dimensions to a bottom radius of 2.90, a top radius of 3.50, and a height of 1.15. After another giggle, Priscilla saw that this was also worse than the baseline at 0.09 kg-eq CO<sub>2</sub> and 1.70 MJ of energy.*

*"Hmm, it seems that short and wide or tall and narrow are both worse. Perhaps the closer my cup gets to the ideal lowest surface-area-to-volume ratio—a globe—the less material it'll use, and the lower impact it'll be." She tried a few new geometries, and found that using a bottom radius of 1.45, top radius of 2.50, and height of 3.00 inches would hold the same volume, AND yielded green bars all around: 0.58 kg-eq CO<sub>2</sub>, 1.1 MJ energy, 4.20e-4 kg-SO<sub>2</sub> air impact, and 3.00e-5 kg-eq PO<sub>4</sub> water impact. The new cup design looked like this:*

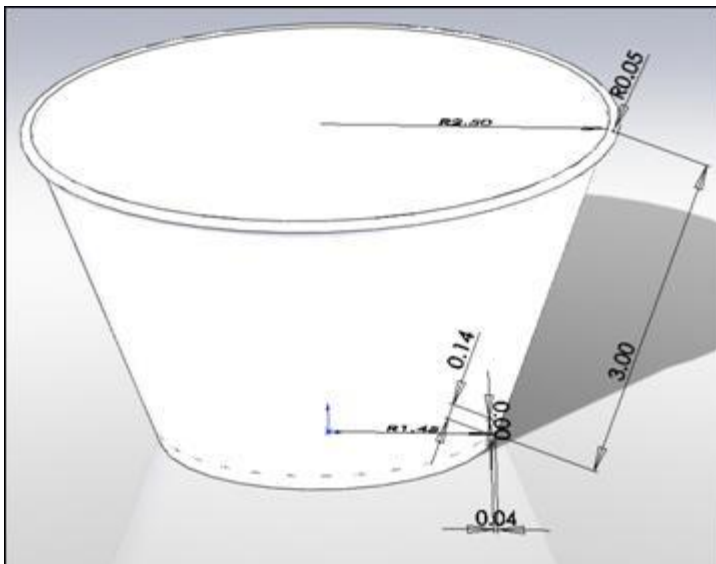

*"It's just a bit less impactful on all four indicators, but that will add up. I wonder how I did against the original model, with both the material and the geometry changes?" Priscilla clicked the "Import Baseline" button to the right of the "Set Baseline" button, and selected her original saved part file in which she had first set the Sustainability parameters using the old geometry and the PET material. The Sustainability dashboard now showed the cumulative effects of her model:*

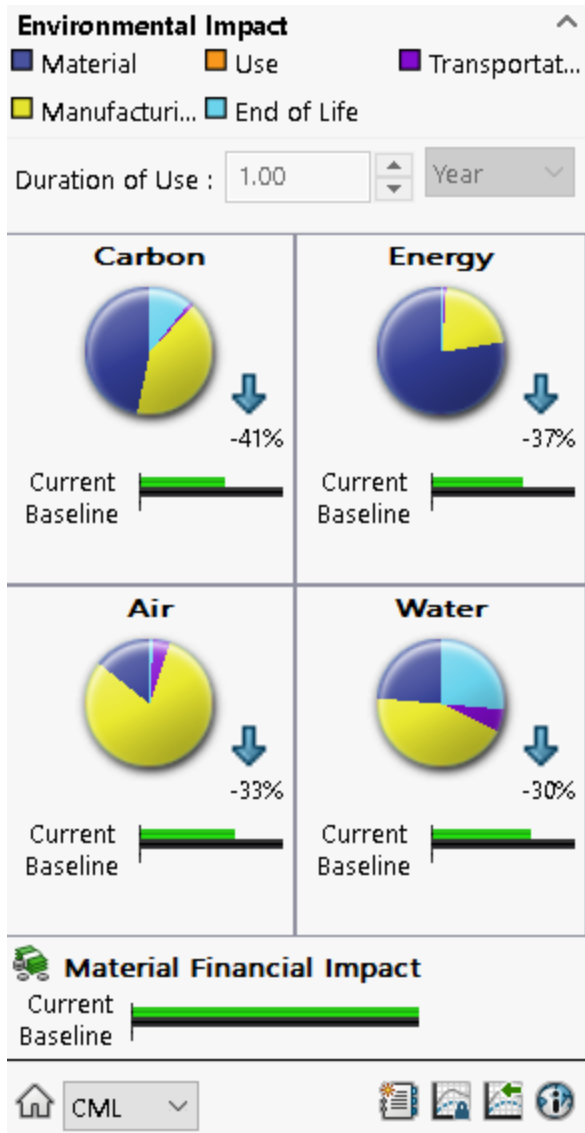

*"Nice work. Let's see how you did comparing your functional unit," said Tom. Priscilla clicked the next button in the sequence, marked "Online Info". This launched the Sustainability Calculator, where Priscilla could type in her actual quantities to compare against several different metrics. She typed in 100 in each quantity box:*

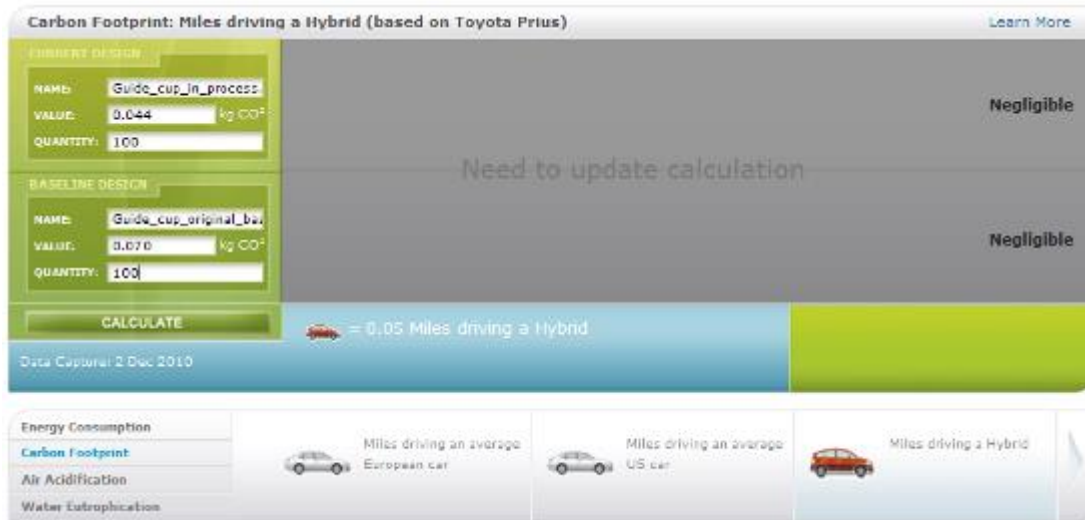

*She hit the "Calculate" button and explored the different ways that Sustainability could show the difference.*

*"This is fantastic!" she said. "I see a 31% reduction in Energy, a 38% reduction in Carbon, a 25% reduction in Water impacts, and my Air impacts become negligible. According to the guidelines for simple products, I can be pretty sure that mine is significantly more sustainable.*

*"So that's four of my five key indicators. I did want to measure the fifth impact domain of human toxicity, though. SOLIDWORKS Sustainability doesn't seem to have any toxicity indicators... what's up with that?"*

#### *Why There Aren't Any Toxicity Indicators in SOLIDWORKS Sustainability*

*The toxicity of a chemical—and its harmfulness to humans—is particularly dependent on the degree of exposure of the chemical, which is hard to track using LCA databases, as they track more global effects. After getting together to debate this very issue, group of the world's leading scientists and LCA practitioners—sponsored by the UN—decided that toxicity models so poorly predicted the real impacts that they shouldn't be used to guide business decisions until the models improved. They produced a document to this effect, called this the Declaration of Apeldoorn after the location of the meeting.*

*"Well I guess that makes sense," said Priscilla. "I'm sure when the toxicity models become useful, they'll add them into SOLIDWORKS Sustainability."*

#### *Tom's Turn*

*Download the model to play along with this example*

*([https://files.solidworks.com/sustainability/Guide\\_fire\\_engine.zip](https://files.solidworks.com/sustainability/Guide_fire_engine.zip)).*

*"Now let's see what I can do for this more complex product! I actually have full Sustainability on my machine," said Tom, "so let me fire it up in assembly mode with my toy model."*



First, Tom went through each of his parts and made sure that each of the parameters—materials and locations—were set for each part. Then, Tom viewed Sustainability at the assembly level, and Priscilla saw a couple new options available:

**Assembly Process** ^

Region:

Asia v



**Use** ^

Region:

North America v





Built to last:

1.00 v Year v

Energy required for assembly process

**Transportation** ^





 12392 km



*“The Assembly Process region is now specifying where the product is assembled, which adds a second transportation leg to each of the individual part manufacturing regions,” Tom explained. “And here, I can specify the primary mode of transportation of this second leg. As with your cup, my toy is assembled in Asia—though not all of the parts are manufactured there, as we discussed earlier—and used in North America, and sent across by ship.”*

*“And what’s that energy box?” Priscilla asked.*

*“That’s where I can specify how much energy is used by my product. It’s given in terms of the energy type consumed over the lifetime of the product—gasoline, diesel, electricity, etc. In my case, I assumed that my toy’s AA battery would be recharged from the grid ten times.”*

*Tom pulled up some figures for AA batteries. “Let’s see,” he said. “An AA battery has a capacity of 2500 milliamp-hours (mAh) at just over a volt, so that’s about 3 watt-hours (Wh) per battery. Ten battery recharges would draw 30 Wh, or 0.03 kWh over the lifetime of the toy.” He entered this value into the Product Lifetime Energy input parameter:*

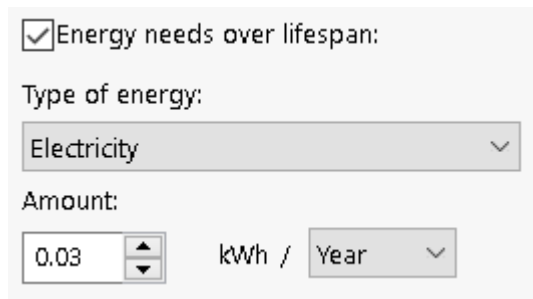

The screenshot shows a software interface for configuring energy needs. It features a checked checkbox labeled "Energy needs over lifespan:". Below this is a dropdown menu for "Type of energy:" with "Electricity" selected. Underneath is an "Amount:" field containing the value "0.03" and a unit selector dropdown set to "kWh / Year".

*Finally, Tom baselined these parameters and looked at the results:*

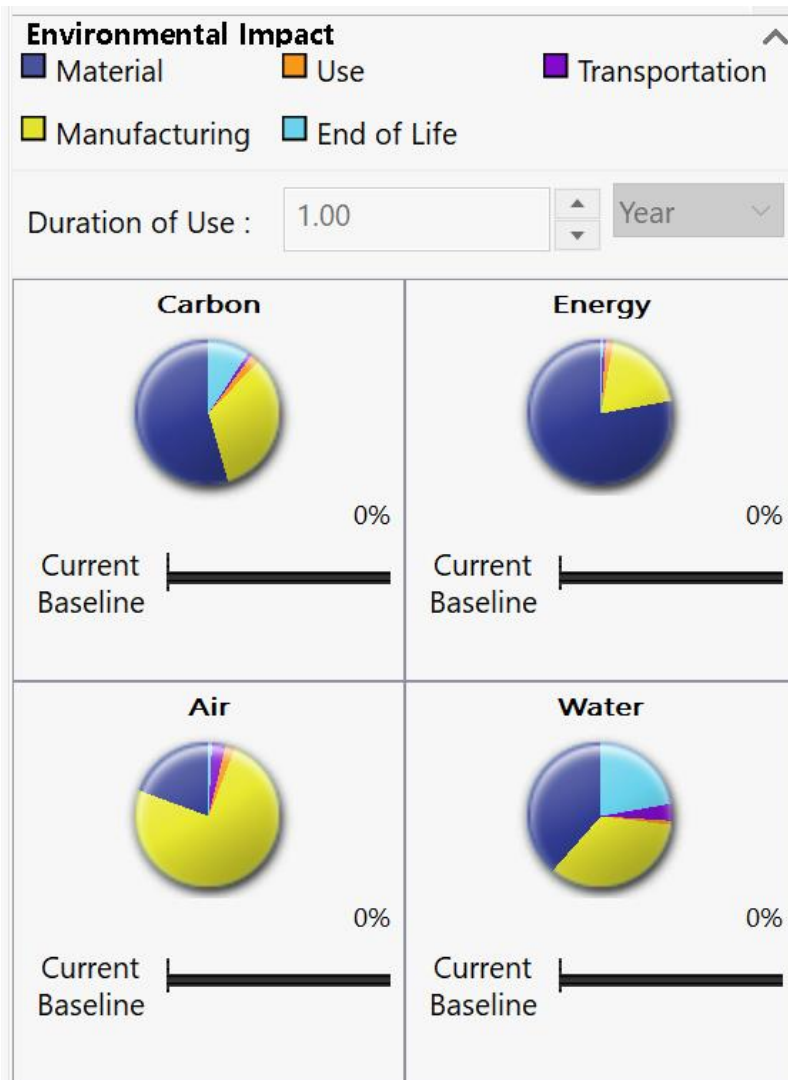

*“You know, I’m surprised at what the charts are showing me,” he said to Priscilla. “I expected the power draw to significantly impact the Transportation and Use phase, but as you can see it’s really pretty negligible. I guess it isn’t hypocritical to be trying to make a lower-carbon battery-powered toy. That’s encouraging!”*

*“What I am seeing,” he continued, “is that the materials, and the manufacturing process associated with these materials, constitute the bulk of the impacts.”*

*“Which ones, though?” asked Priscilla. “This toy has a lot of different parts of different materials.”*

*"I know, and I don't want to open each one to look at its individual Sustainability results. Let's look at this through the Assembly Visualization tool."*

*Tom opened Assembly Visualization, which Priscilla had seen used before for viewing components by, say, total weight. Tom showed her how he could add a custom column for any of the Sustainability metrics:*

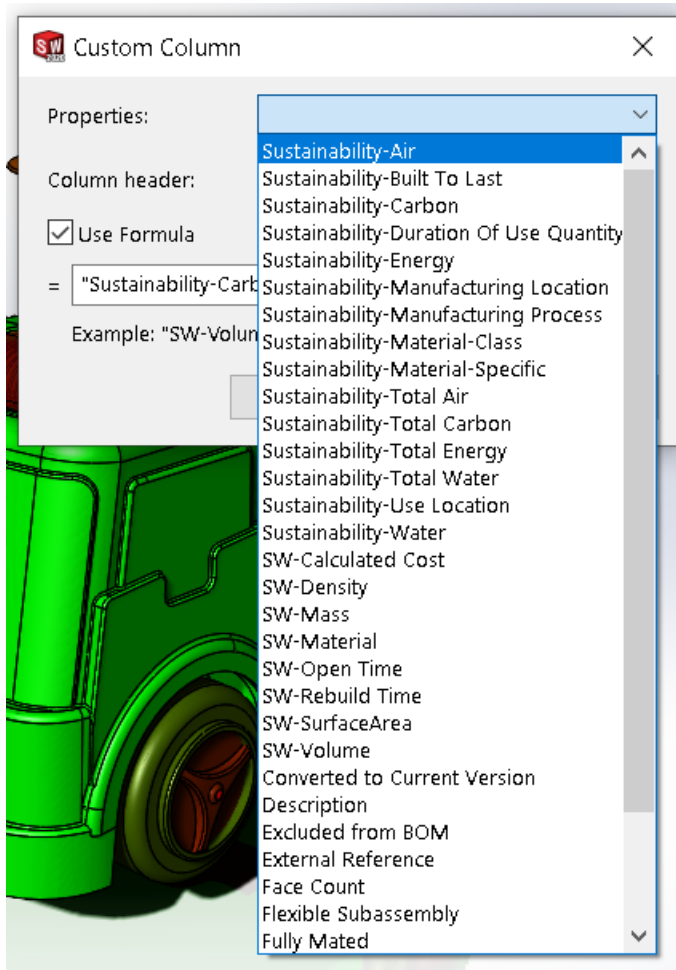

Since Tom wanted to get an estimate of his carbon footprint, he wanted to use one of the carbon properties. He chose “Total Carbon”, which grouped together multiple instances of parts, to view for instance the effect of all four wheels together. He added this column and clicked on it to sort the parts by this indicator. Finally, Tom set the visualizing spectrum to meaningful colors and moved the slider to an appropriate cutoff:

File Name	Quantity	Sustainability-Total Carbon
Top main shell	1	0.31
Chassis	1	0.308
Rear_Wheel	4	0.248
Transmission Casing	1	0.109
Hub1	4	0.084
fireman	1	0.065
Knob1	1	0.021
Speaker	1	0.016
Ladder	1	0.013
Siren_R1	1	0.0098
MirrorSiren_R1	1	0.0098
Battery_Cover	1	0.0062
Rear_Axle	2	0.003
Battery_Plate	1	0.0022
Button1	1	0.002
Battery_PlateA(Mi...	2	0.00052
Battery_Spring	1	0.000071

*“There,” said Tom. “Now I can see pretty clearly what the most impactful parts are in my model.” He showed Priscilla the resulting color-coded assembly:*

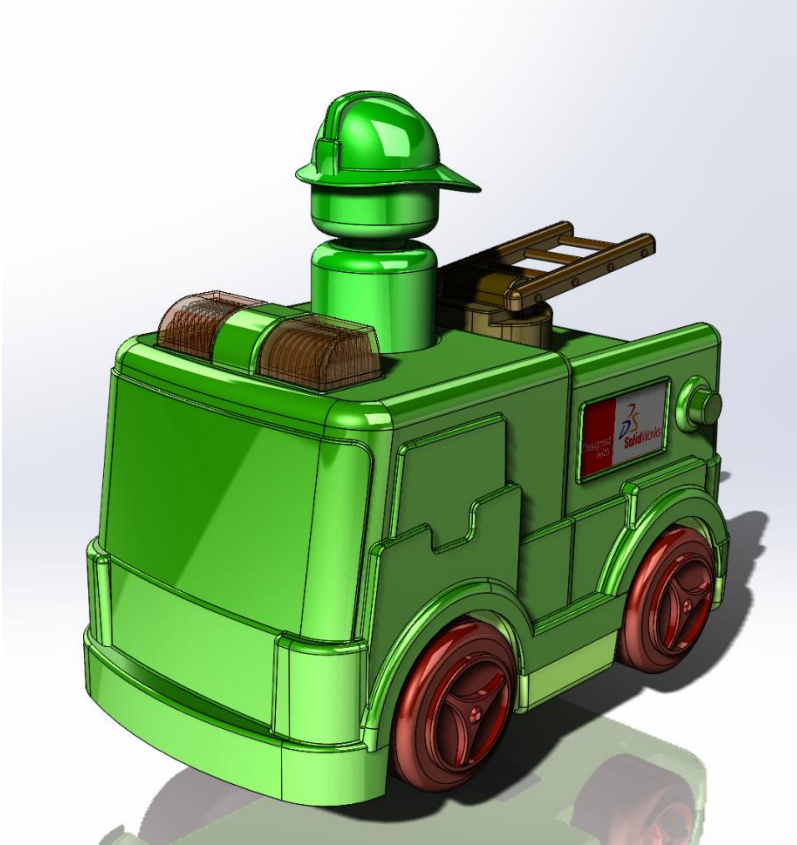

*“From the sorting and the model, I can clearly see that the wheels and the hub are the main parts that I should focus on when I redesign my toy. In fact, I can already see that there are a lot of materials that are less impactful than ABS, so I can lower the footprint substantially; and it’s great to know that working with my suppliers to see what different materials are available to me within the target cost-of-goods range will really make a difference, rather than looking at the transportation or the power use.*

*To make sure that Tom wasn’t missing any internal components that had significant impacts, Tom cross-sectioned the view to look inside:*

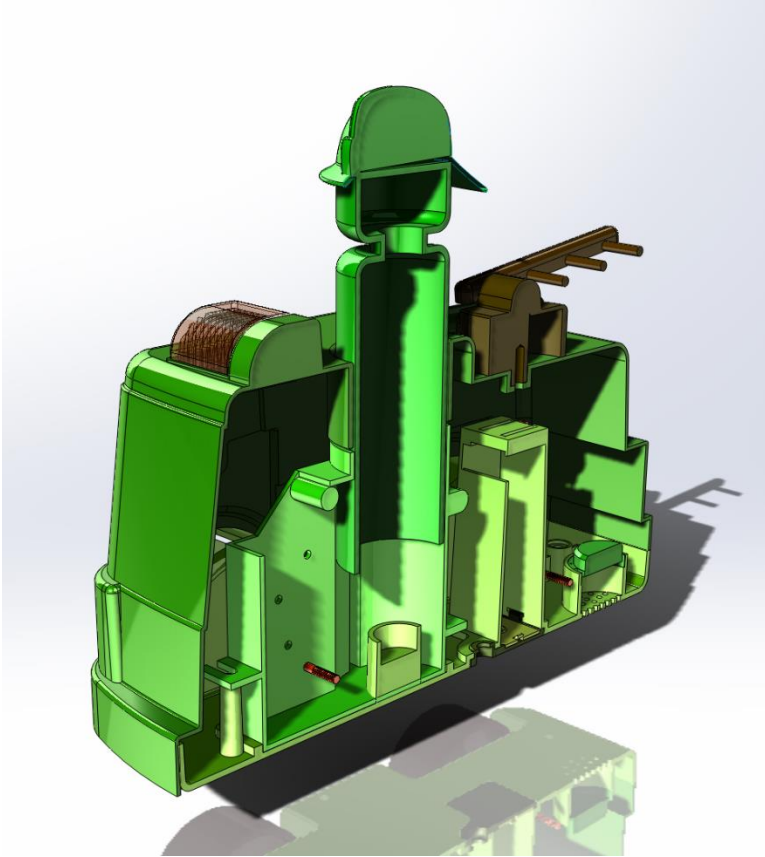

*"I know what I should focus on, and I have a quick sense of my carbon footprint. Now let me generate a report that I can take to the rest of my team to show them what I've found."*

*Tom checked out a couple critical items in the report, such as a snapshot of the impact dashboard...*

## Sustainability Report

Model Name: Assem1

Weight: 0.21 kg  
Built to last: 1.0 year  
Duration of use: 1.0 year

### Environmental Impact (calculated using CML impact assessment methodology)

#### Carbon Footprint



1.2 kg CO<sub>2</sub>e

Material:	0.716 kg CO <sub>2</sub> e
Manufacturing:	0.300 kg CO <sub>2</sub> e
Use:	0.00 kg CO <sub>2</sub> e
Transportation:	0.028 kg CO <sub>2</sub> e
End of Life:	0.115 kg CO <sub>2</sub> e

#### Total Energy Consumed



22 MJ

Material:	17 MJ
Manufacturing:	4.3 MJ
Use:	0.00 MJ
Transportation:	0.417 MJ
End of Life:	0.084 MJ

#### Air Acidification



4.6E-3 kg SO<sub>2</sub>e

Material:	2.3E-3 kg SO <sub>2</sub> e
Manufacturing:	2.0E-3 kg SO <sub>2</sub> e
Use:	0.00 kg SO <sub>2</sub> e
Transportation:	1.8E-4 kg SO <sub>2</sub> e
End of Life:	5.8E-5 kg SO <sub>2</sub> e

#### Water Eutrophication



5.3E-4 kg PO<sub>4</sub>e

Material:	2.8E-4 kg PO <sub>4</sub> e
Manufacturing:	7.4E-5 kg PO <sub>4</sub> e
Use:	0.00 kg PO <sub>4</sub> e
Transportation:	3.3E-5 kg PO <sub>4</sub> e
End of Life:	1.4E-4 kg PO <sub>4</sub> e

...And a look at the top three most impactful components:



## Sustainability Report

Model Name: Assem1









































Weight: 0.21 kg

Built to last: 1.0 year

Duration of use: 1.0 year

### Component Environmental Impact

Top Ten Components Contributing Most to the Four Areas of Environmental Impact

Component	Carbon	Water	Air	Energy
Top main shell	0.290 	1.3E-4 	1.1E-3 	5.5 
Chassis	0.288 	1.3E-4 	1.1E-3 	5.4 
Transmission Casing	0.102 	4.6E-5 	4.0E-4 	1.9 
Rear Wheel	0.058 	2.6E-5 	2.3E-4 	1.1 
fireman	0.056 	2.0E-5 	2.1E-4 	1.4 
Hub1	0.019 	8.6E-6 	7.6E-5 	0.363 
Knob1	0.018 	6.5E-6 	6.6E-5 	0.439 
Speaker	0.017 	6.1E-6 	8.8E-5 	0.258 
ladder	0.012 	4.2E-6 	4.3E-5 	0.284 
MirrorSiren_R1	0.011 	4.2E-6 	3.8E-5 	0.171 

Tom's full sustainability report is included in the fire\_engine.zip file ([https://files.solidworks.com/sustainability/Guide\\_fire\\_engine.zip](https://files.solidworks.com/sustainability/Guide_fire_engine.zip))

*"This information gives me a screening-level look at the starting point for redesigning my toy, as well as ballpark figures of what I'll eventually be able to use in my marketing, once I perform a full Life Cycle Assessment on the redesigned product."*

*And with that, Tom and Priscilla started redesigning the toy fire engine. Can you come up with a lower carbon number than the final design they were able to produce?*

## Chapter 7: The Sustainable Design Strategies

Looking at impacts in the context of lifecycle stages is a good way to measure them, but not as helpful when actually designing or redesigning; after all, sustainable design strategies often affect more than one stage.

Let's look at a few of the strategies that Tom and Priscilla employed.

Level 1: Product Design - Parametric Optimization

Level 2: Product Development - Fundamentally Altering the Product

Level 3: Product Innovation - Changing the System

### Level 1: Product Design - Parametric Optimization

We've focused in these initial examples on parametric optimization that is, taking specific steps to incrementally reduce material and energy impacts. This often results in quick, low-hanging-fruit reductions in the overall product impact. Here are some strategies we saw in action:

#### Sourcing Locally

Priscilla's first attempt was to move the manufacturing operation closer to the region of use. As she found out, this is often highly dependent on the modes of transportation being compared, not just the distances involved. Generally speaking, the modes of transportation listed in decreasing order of environmental impact are:

1. Air transport
2. Truck transport
3. Rail transport
4. Ship transport

Besides distance and mode, another transportation factor is the quality of the fuel used, which is also regionally dependent. Fuel sourced in Asia often has a higher sulfur content, for example, raising the acidification potential of the transport leg. It is assumed that the fuel is sourced in the region of origin for each transportation leg.

The transportation impacts of changing the manufacturing region may be outweighed by the regional differences in manufacturing, however. Manufacturing energy—in the form of thermal energy (natural gas, steam generation, etc.) and electrical energy—vary in amounts, efficiencies and sources in different regions. The grid mix in the region of manufacture has an impact on the energy and other indicators in the Manufacturing phase.

#### Alternate Material Selection.

Priscilla's second tactic was to find a different material for her cup. Materials that designers and engineers select should satisfy four criteria:

1. The material must function as intended;
5. The material must provide the right aesthetic, ergonomic, and other form considerations;
6. The material's cost must be in the range of the product's cost of goods; and

7. The material's environmental impacts should be minimized.

Too often, we optimize for the first three criteria and ignore the fourth. Priscilla worked through the “Find Similar” material selection tool to find a material that satisfied all four criteria.

Priscilla was quite surprised to find that High-Impact Polystyrene (HIPS) satisfied all four criteria, including lower environmental impacts, than her original PET. Sometimes our assumptions about materials—like polystyrene, PVC, or various metals—are based more on negative press than on scientific data. By working with data-driven tools like SOLIDWORKS Sustainability, we can sharpen our intuitions about material impacts.

Lightweighting (also called source reduction).

Finally, Priscilla re-examined the geometry of the cup to see if she could use less material to hold the same volume of liquid. Lightweighting, or source reduction, is one of the most common ways to optimize for greener designs, especially since this reduces overall material costs as well.

One critical consideration for load-bearing materials that are being lightweighted is to ensure that the product still has enough strength to perform as intended, within an appropriate factor of safety. SOLIDWORKS has powerful Simulation tools that can be used in concert with Sustainability to optimize strength and reduced impact, which we'll explore in future examples.

### Level 2: Product Development - Fundamentally Altering the Product

Tom struggled with this level of redesign in the discussions of his functional unit and system boundary. He wanted an “interactive toy”, but is a battery-operated speaker and lights the only way to achieve interactivity? What happens to the environmental impact if the parent replaces the rechargeable battery with disposables, is drawing power from batteries “dirtier” than drawing power from the grid? And what of the batteries' impact at end of life?

Tom could fundamentally change his product to be one that wasn't battery-operated, but still interactive. The only way to know if he should focus his efforts on the battery would be to include it in the environmental impact calculations. We'll talk about ways to model this when we revisit Tom's fire engine.

### Level 3: Product Innovation - Changing the System

Finally, Priscilla thought early in the process about the system in which she was producing her cup. Product innovation and system redesign goes beyond product design, and touches upon reconsidering people's behaviors, and the way they interact with the product system. She felt that her plastic cup wasn't a strictly necessary product in all situations, and that perhaps a reusable metal cup would mean a lower overall impact if more people were to adopt the practice of carrying or offering these. We'll take a look at this system redesign in the future, and consider how to compare these two models and their associated behaviors.

## Chapter 8: Communicating the Results

Product development is a process that touches many parts of an organization and its various partners and customers. Sustainable design can generate innovative and attractive solutions, but they may never see the light of day unless the features and benefits can be communicated effectively.

This section outlines some ways to communicate the value of sustainable solutions to several of the major stakeholders involved with most products.

To designers and engineers unfamiliar with sustainable design

To general management

To other parts of the supply chain

To sales & marketing

### To designers and engineers unfamiliar with sustainable design

As was discussed in the opening section of this guide, sustainability can mean many things to people. For perhaps the majority of designers it doesn't actually mean anything in particular. Then there are the engineers who have the impression that it is "touchy-feely," totally optional, not their problem, and too expensive.

Instead of trying to go through all of the aspects of sustainable design, describing functional units, midpoint categories, and so on, it is best to focus on common values. For instance, it may make more sense to talk about sustainable design as a set of tools designed to identify and decrease waste. This waste can come in the form of excess energy, pollutants, material ending up in landfills, and other non-valuable by-products generated over the life cycle of an item. Most environmental impact metrics actually represent explicit or inherent waste in the system, so comparing product designs can usually lead to the identification of lower waste options.

In certain sectors, sustainable design represents a way to incorporate regulatory considerations in the design process. When certain chemicals or materials cannot be used, such as in the case of the EU's Restriction of Hazardous Substances Directive (RoHS), LCA tools can help identify useful alternatives that do not have the same hazardous impacts.

### To general management

In an organization striving to be a sustainable company, as described earlier, sustainable design need little explaining. In fact, in some cases there may be such lofty ambitions for sustainable design that the trade-offs identified by impact assessments need to be used to ground the conversation.

In companies where sustainability has become a focus, engineers have an excellent opportunity to engage with management around the goals and priorities that decisions about the products should reflect. Some tools and approaches may fit better than others, depending on expected outcomes. For instance, an industry-wide scorecard will be more useful than an in-depth LCA if the purpose is to benchmark and communicate with other companies. Furthermore, there needs to be discussion about how to handle trade-offs between environmental impacts and other considerations, such as cost. These are business decisions, which are exactly what engineering and management need to navigate together.

Sometimes product developers will need to discuss sustainability with business people in the organization who either don't understand it or who don't think it is a priority. As with engineers, the key is to translate environmental impact considerations into terms that these people do care about. In the case of management, two great examples are profitability and risk management.

Profit is the result of revenue minus cost. Therefore, anything that can be presented as either an increase in revenue or a decrease in cost will get people's attention. Because most environmental impact studies do not show financial considerations, it may be necessary to extrapolate how more environmentally responsible products can increase revenue, perhaps through premium pricing or better competitive positioning. Cost reduction is an easier case to make since, as described above, excess environmental impacts are an expression of waste.

Environmental impacts also translate well into risks. The more that a company can do to decrease the negative impacts its products have on human health and the environment, the less likely to be unwanted repercussions for which the company could be held accountable. Of course, sustainable design doesn't guarantee product safety. It is certainly possible to create environmentally-responsible, socially-irresponsible items, but even normal items still rely on attentive design (eco-designed baby toys can still be a choking hazard). Still, linking impact decisions to risk management can help clarify the importance of sustainable design.

### To other parts of the supply chain

In order to do a useful assessment, it is often necessary to get information from suppliers about the contents, processing techniques, manufacturing locations and so on for the components they provide. Sharing impact results with suppliers can help them adjust their own processes, or at least explain why the company is making certain sourcing and materials choices.

In some cases, organizations have the ability to demand that their suppliers abide by certain criteria. This can range from simply reporting their product's composition to full environmental impact assessments. For example, Wal-Mart requires its suppliers to fill out a "Packaging Scorecard" as part of its efforts to reduce packaging throughout its supply chain. Although there aren't specific thresholds they have to meet, Wal-Mart says that it will take the results into account in making sourcing decisions.

Of course this works in reverse if the company doing the sustainable design is itself a supplier. By generating parts that take into account environmental impact, they are influencing the sustainability of downstream products. It also makes it easier to comply with any impact requirements or guidelines the customer may have.

A common way to communicate impact data is through EPDs. Environmental Product Declarations are a standardized (ISO 14025/TR) representation of LCA results. They require a full ISO-compliant LCA and build on the resulting quantified impact data certified by an independent third-party. It is solely an internationally recognized format for presenting LCA data and not an evaluation or rating system.

### To sales & marketing

There are many times when information about the environmental impact of a product never reaches the customer. If it is not relevant to the product's purchase or use, the information can just stay "behind the scenes." However, there are two main reasons why impact information is shared with customers: to promote its sustainability as a specific product benefit, and to show that the product meets certain standards. In both cases, it is very important that sales and marketing people understand the regulations that apply to making environmental impact claims.

In the first case, it is often tempting to promote a product's sustainability. Green marketing is on the rise and many customers are starting to pay attention to environmental and social impacts in making buying

decisions. Unfortunately, some organizations have gotten a little overzealous in their claims, often leading to accusations of “greenwashing.” As a result, the Federal Trade Commission has issued a set of Guides for the Use of Environmental Marketing Claims, known more popularly as the Green Guides. These guides lay out principles and guidelines to help marketers avoid making claims about environmental benefits that are considered unfair or deceptive, as defined by Section 5 of the FTC Act.<sup>33</sup>

The second way in which environmental impact information is represented to customers is through criteria-based labeling programs. First, it is important to note that there are ISO standards in the 14000 family that apply to environmental labeling and life cycle assessment. These specify how LCA results can be used and what labeling can claim. Products can be certified as ISO compliant and labeled as such. In addition, there are many criteria-based certification programs for which products can qualify. Well known examples include EnergyStar, FSC (Forest Stewardship Council), and EPEAT (Electronic Product Environmental Assessment Tool).

Another important consideration in promoting the sustainability of a product is whether it is visibly “green” or whether its “greenness” is less apparent. A product that has an outer shell of bamboo, instead of plastic for instance, is in many ways its own advertisement. SimpleTech’s [re]drive external USB hard drive has some good energy-saving capabilities designed into it, but the fact that its case is largely bamboo helps customers identify it as a “green” option right away. Meanwhile, in many situations, the best ways to reduce a product’s impacts are invisible to the user and need much more explicit advertising. For instance, the EnergyStar label can help identify products that use less power than their nearly identical-looking peers.

## Chapter 9: Next Steps

Now what? Given all of the information in this guide, it might be hard to figure out exactly what to do, or do differently, on the proverbial Monday morning. Developing your skill in sustainable design will take some time, but there are plenty of ways to put these tools and techniques into practice immediately.

If your company or industry has any sort of sustainability scorecard, use it to assess your current design or an existing company product or component. If there isn’t a specific scorecard that applies to your context, one like the 3M example given earlier or the LiDS Wheel can work. More important than getting it “right” at this point is determining what is difficult to score and what is more straightforward. Did you have enough information? If so, where did it come from and is it reliable? If not, how would you find it? Once you have done this for one product, do it for another one or for a design idea to get comfortable using these methods to compare options. If you are at a loss for examples use some general ones, such as glass bottles versus plastic ones, or paper bags versus plastic ones. A little research should turn up enough information about those products to get you started.

An easy place to start with data-based life cycle analysis is with the downloadable SOLIDWORKS models, if you’re a SOLIDWORKS customer and user. If you have SOLIDWORKS, you can use SustainabilityXpress for SOLIDWORKS parts, since it’s a standard component of the software. There’s value in learning to use the software, but more importantly, you can start to see the impacts that your various design decisions have on the environment. This is a good way to test your intuition as well. Are there environmental

---

<sup>33</sup> <https://www.ftc.gov/news-events/press-releases/2012/10/ftc-issues-revised-green-guides>

impacts from some materials that surprised you? Is there a greater or smaller difference between options than you would have thought? Most sustainable design entails narrowing down options and making trade-offs, so the more you have a basic feel for some of the impacts the easier it will be to find those changes that are meaningful and significant.

Once you have developed some familiarity with the concepts, frameworks, and design and decision support tools, it is important to incorporate them as often as possible, even when others aren't. There is nothing wrong with having greater insight into your products than is expected. Hopefully, however, you will be able to discuss the impacts and implications with your fellow designers as well as others in your organization and its partners.

For those who want to be acknowledged as proficient with SOLIDWORKS Sustainability, there is a two-level certification program under development. You may be familiar with the traditional Certified SOLIDWORKS Associate (CSWA) certifications; SOLIDWORKS developed an analogous certification for sustainable design, the Certified Sustainable Design Associate (CSDA)<sup>34</sup>. If you've managed to read through to this section, rejoice in the fact that you're armed with enough knowledge to pass the CSDA!

If you are interested in becoming an LCA expert, there are numerous guides and courses that can develop the in-depth knowledge of the LCA process. Once you have gained hands-on experience, there is an exam-based qualification program developed by The American Center for Life Cycle Assessment for those interested in being designated as an LCA Certified Professional (LCACP). Note that the focus of this sort of LCA expertise is on assessment, and not on product design and development processes.

Lastly, try to connect with other developers, designers, and engineers working to incorporate sustainability principles into their work. There is a great deal of research about sustainable design available and underway, with plenty of academics interested in exploring the topic. There are professional networks and organizations around the world. There is a partial list at the end of this guide to get you started, but more are arising all the time. Whether you have come to this guide because you wanted to or because you had to, you will find that there are plenty of people who can guide you and resources that can help you succeed at sustainable design.

## Chapter 10: For More Information

Appendix A - Reference Materials

Appendix B - A Deeper Look at the LCA Process

Appendix C - LCA Tools and Methods

[Appendix A - Reference Materials](#)

Sustainability & Sustainable Business

Berkshire Encyclopedia of Sustainability, Vol. 1-10, Berkshire Publishing Group (2009-2011)

[www.EnvironmentalLeader.com](http://www.EnvironmentalLeader.com)

[www.GreenBiz.com](http://www.GreenBiz.com)

---

<sup>34</sup> <https://www.SOLIDWORKS.com/certifications/sustainability-cswa-sustainability>

<https://SustainableBrands.com/corporate>

Sustainable Living

[www.TreeHugger.com](http://www.TreeHugger.com)

[www.inhabitat.com](http://www.inhabitat.com)

[www.grist.org](http://www.grist.org)

### The Hannover Principles

Sections of this guide detail specific environmentally responsible design strategies. The “Hannover Principles” are a good place to start.<sup>35</sup> They are, in summary:

1. Insist on rights of humanity and nature to co-exist.
2. Recognize interdependence between the elements of human design and the natural world.
3. Respect relationships between the human values and matter.
4. Accept responsibility for the consequences of design decisions.
5. Create safe objects of long-term value.
6. Eliminate the concept of waste.
8. Rely on natural energy flows.
9. Understand the limitations of design.
10. Seek constant improvement by the sharing of knowledge.

For more information, see <http://www.c2c-centre.com/library-item/hannover-principles>

### Appendix B - A Deeper Look at the LCA Process

The specific process of Life Cycle Assessment (LCA) has a standardized set of steps and outputs in the form of environmental impact measures.<sup>36</sup> It is defined as “an objective process to evaluate the environmental burdens associated with a product, process, or activity by identifying energy and materials used and wastes released to the environment, and to evaluate and implement opportunities to affect environmental improvements.”<sup>37</sup>

The standardized LCA process has four major steps:

1. Goal and Scope Definition – What are we trying to learn?
2. Life Cycle Inventory (LCI) – What’s embedded in the product?
3. Life Cycle Impact Assessment (LCIA) – What effects does it have?
4. Data Interpretation – What does it all mean?

---

<sup>35</sup> Developed in 1992 by William McDonough and Michael Braungart for the Expo 2000 World’s Fair, Hannover, Germany.

<sup>36</sup> LCAs are part of the ISO 14000 (environmental management) standards, and are specifically addressed by ISO 14040:2006 and 14044:2006.

<sup>37</sup> Society of Environmental Toxicology and Chemistry (SETAC), 1990



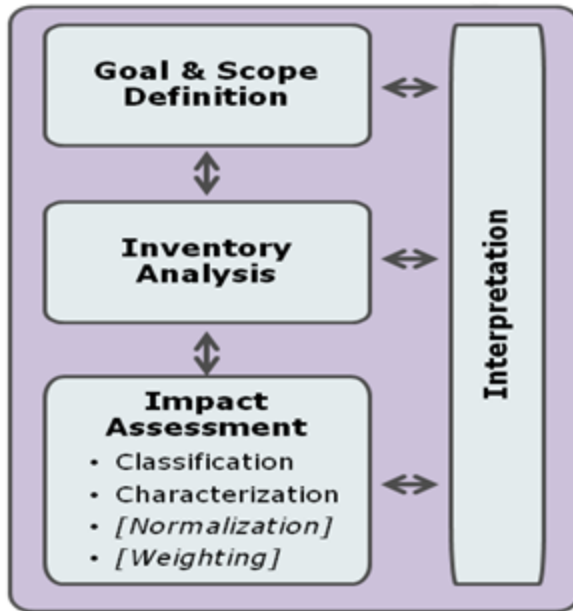

### Goal & Scope Definition

As with other assessments, it is important to clarify the purpose and extent of the LCA. A Goal & Scope document will consider to the following questions.

#### 1. What are we trying to understand?

LCAs are designed to address such questions as:

- What activities in the product's lifecycle contribute most to its overall environmental impact?
- What are the environmental consequences of changing a step in its production?
- What are the environmental consequences of changing the materials in the product?
- What are the environmental consequences of using recycled rather than virgin material for the product?
- What is the environmentally-preferable choice among products A, B or C?
- How does this product compare to its previous version?

LCAs usually do not address such things as social impacts or financial considerations so must be used in conjunction with other decision support tools.

#### 2. What is the *functional unit*?

In order to compare two product systems, it is necessary to choose a measure of the function of the systems that is consistent between the two. For instance, for a coffee maker it might be cups brewed, for laundry detergent it could be washing cycles, for paint it could be surface protection over time.

#### 3. What *environmental impacts* should we consider?

A great deal of attention has been given to greenhouse gas emissions, with some organizations focusing mainly on their resulting carbon footprint, although this is just a subset of all of the possible environmental impacts that can be assessed. It is up to the organization to decide what factors are important to them.

#### 4. What are we comparing?

LCAs are only useful when used to compare options. A given product can be compared to previous versions, competitive offers, alternative design options, industry benchmarks, target impact levels, etc.

#### 5. What is our *system boundary*?

Product life cycles intersect a great many processes, some more directly linked to the product itself than others. An assessment cannot cover everything so system boundaries clarify what it will include. The following figure shows a possible system boundary chart for a styrofoam cup.

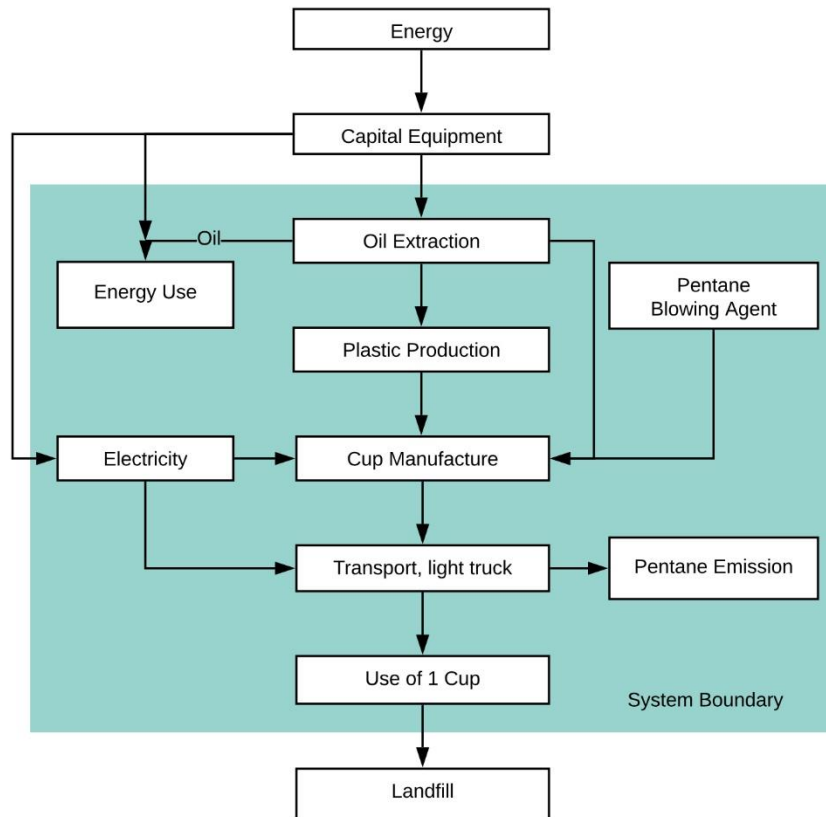

Source: Design + Environment, Lewis & Gertsakis

Some of the standard product life cycle scopes include:

- Cradle to grave – Usually denotes all phases from raw materials through disposal
- Cradle to cradle – Like cradle to grave except that it tracks where the product’s elements go after end of use, with special attention to recycling and reuse
- Cradle to gate – Includes all phases up until it leaves production (the factory gate), bound for the customer, since this is the end of most manufacturer’s ability to directly influence impact
- Gate to gate – A very narrow LCA, just focused on only one particular phase of the production process

## 6. What assumptions should we make?

Whether it’s product usage behavior, availability of raw materials, manufacturing capacity, or any number of variables affecting a product’s actual life cycle, LCAs require assumptions. They are unavoidable so the key is to identify and document them.

## 7. What are the data requirements and level of detail?

Data on actual product life cycles is more accurate, but much more expensive, labor intensive, and time consuming to collect than data from tables based on generalized information. The right balance depends on how the results will be used, as well as on data source access.

## 8. How do we allocate the burden of byproducts and other process complexities?

In many production processes, coupled or by-products occur, raising the question: To which product should these impacts be allocated? Assigning all the impacts to one product leads to “falsely benign” by-products. Methods for distributing multi-product impacts include allocating them by mass, energy value, market value, exergy, or substance content.

The depth and intensity of the LCA can be decided based on the answers to these questions. A “full” LCA would include actual environmental impact data gathered once the product has actually gone through its entire life cycle. Such detailed LCAs can take months and thousands of dollars to do and are, by definition, only possible to complete once the product is in use and has gone through all phases of its life cycle. This increased accuracy may be worth it for benchmarking or reporting purposes.

It is also possible to do an “LCA light,” using generalized data tables and educated assumptions about an item’s production and use. While not as accurate as LCAs reflecting actual impacts, they can be done relatively quickly and with a high degree of confidence in the results with the data sets and software tools available, even by people without in-depth LCA training. Perhaps most importantly, they can be done during product development and planning stages, allowing environmental impact considerations to play a part in design decisions.

## Inventory Analysis

The next phase entails creating a list of all of the components of the products life cycle that fall within the defined system boundary. It has three major steps:

- Construct a process flowchart that shows the following:
  - Raw materials
  - Mfg processes

- Transports
- Uses
- Waste management
- Collect data for:
  - Material inputs
  - Products and byproducts
  - Solid waste, air and water emissions
- Calculate the amounts of each in relation to the functional unit

The resulting Life Cycle Inventory (LCI) provides a breakdown of all of the energy and materials involved in a product's system at a level of detail that provides a basis for evaluation.

### Impact Assessment

Once a detailed LCI is created, environmental impacts can be ascribed to its parts, and if desired to the whole system. There are four steps to the Life Cycle Impact Assessment (LCIA) process, the first two of which are considered mandatory, while the last two are optional.<sup>38</sup>

#### 1. Classification

Classification involves assigning specific environmental impacts to each component of the LCI. It is here where decisions made during the scope and goal phase about what environmental impact categories are of interest come into play. The figure below shows one well-known set of classifications, called midpoint categories, and how they map to domains of damage they cause.<sup>39</sup>

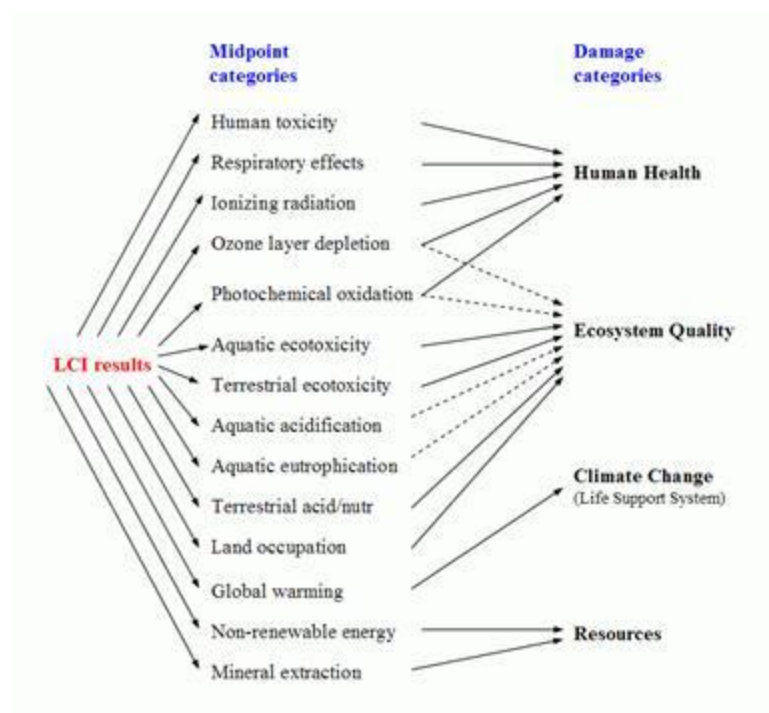

<sup>38</sup> As dictated by the ISO 14044 standard

<sup>39</sup> Adapted from "IMPACT 2002+" LCIA methodology / Dr. Olivier Jolliet, Univ. of Michigan

Commonly Used Impact Categories<sup>40</sup>

Impact Category	Scale	Examples of LCI Data (i.e. classification)	Common Possible Characterization Factor	Description of Characterization Factor
Global Warming	Global	Carbon Dioxide (CO <sub>2</sub> ) Nitrogen Dioxide (NO <sub>2</sub> ) Methane (CH <sub>4</sub> ) Chlorofluorocarbons (CFCs) Hydrochlorofluorocarbons (HCFCs) Methyl Bromide (CH <sub>3</sub> Br)	Global Warming Potential	Converts LCI data to carbon dioxide (CO <sub>2</sub> ) equivalents Note: global warming potentials can be 50, 100, or 500 year potentials.
Stratospheric Ozone Depletion	Global	Chlorofluorocarbons (CFCs) Hydrochlorofluorocarbons (HCFCs) Halons Methyl Bromide (CH <sub>3</sub> Br)	Ozone Depleting Potential	Converts LCI data to trichlorofluoromethane (CFC-11) equivalents.
Acidification	Regional Local	Sulfur Oxides (SO <sub>x</sub> ) Nitrogen Oxides (NO <sub>x</sub> ) Hydrochloric Acid (HCL) Hydroflouric Acid (HF) Ammonia (NH <sub>4</sub> )	Acidification Potential	Converts LCI data to hydrogen (H <sup>+</sup> ) ion equivalents.
Eutrophication	Local	Phosphate (PO <sub>4</sub> ) Nitrogen Oxide (NO) Nitrogen Dioxide (NO <sub>2</sub> ) Nitrates Ammonia (NH <sub>4</sub> )	Eutrophication Potential	Converts LCI data to phosphate (PO <sub>4</sub> ) equivalents.
Photochemical Smog	Local	Non-methane hydrocarbon (NMHC)	Photochemical Oxident Creation Potential	Converts LCI data to ethane (C <sub>2</sub> H <sub>6</sub> ) equivalents.
Terrestrial Toxicity	Local	Toxic chemicals with a reported lethal concentration to rodents	LC50	Converts LC50 data to equivalents; uses multi- media modeling, exposure pathways.

<sup>40</sup> "Life Cycle Assessment: Principles and Practice," Scientific Applications International Corporation, EPA/600/R-06/060 (May 2006), pg. 49.

Aquatic Toxicity	Local	Toxic chemicals with a reported lethal concentration to fish	LC50	Converts LC50 data to equivalents; uses multi-media modeling, exposure pathways.
Human Health	Global Regional Local	Total releases to air, water, and soil.	LC50	Converts LC50 data to equivalents; uses multi-media modeling, exposure pathways.
Resource Depletion	Global Regional Local	Quantity of minerals used Quantity of fossil fuels used	Resource Depletion Potential	Converts LCI data to a ratio of quantity of resource used versus quantity of resource left in reserve.
Land Use	Global Regional Local	Quantity disposed of in a landfill or other land modifications	Land Availability	Converts mass of solid waste into volume using an estimated density.
Water Use	Regional Local	Water used or consumed	Water Shortage Potential	Converts LCI data to a ratio of quantity of water used versus quantity of resource left in reserve.

## 2. Characterization

Once the impact categories have been identified, conversion factors – generally known as characterization or equivalency factors – use formulas to convert the LCI results into directly comparable impact indicators. This allows different types of plastics and metals to be compared as to their impacts on Global Warming, for instance. The table above gives some commonly used characterization factors for each impact category.

There are well over a dozen categorization and characterization methods.<sup>41</sup> Each maps materials to impacts based on scientific research, with many materials having impacts in multiple categories. Classification is usually facilitated by software that can take the component inputs and calculate allocated impacts based on either actual data gathered or standardized data tables. While there are pros and cons to each classification tool, some have been adopted more broadly than others.

## 3. Normalization (optional)

---

<sup>41</sup> For a good overview of many of the major methods, see Appendix B: LCA and LCI Software Tools in “Life Cycle Assessment: Principles and Practice,” Scientific Applications International Corporation, EPA/600/R-06/060 (May 2006), pp. 74-77.

Some practitioners choose to normalize the impact assessment by scaling the data by a reference factor, such as the region’s per capita environmental burden. This helps to clarify the relative impact of a substance in a given context. For instance, if global warming contributions are already high in the context in which the product is being assessed, a reference factor would normalize whatever the product’s global warming contributions are in order to clarify its relative impacts.

#### 4. Weighting (optional)

This process entails combining all of the indicators together, each with its own weighting, to create a single “score” that reflects a certain prioritization of the importance of each type of impact. Weighting is more of a political than scientific process since giving, say, global warming’s score more weight than acidification’s is a values-based decision. Stakeholders may differ significantly on their views about the importance of impacts, as shown in the chart below.<sup>42</sup>

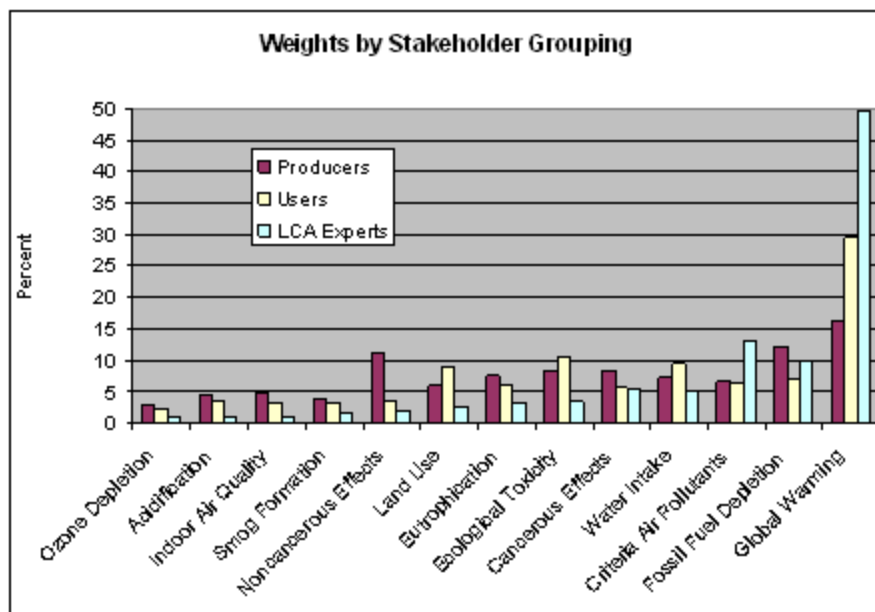

Many practitioners choose to leave the impact scores broken out into categories, with no weighting at all. Although this approach creates a more complicated report, it enables impact comparisons between products on a more granular level.

Weighted “single score” LCAs have the advantage of generating one, easy-to-communicate impact number, often expressed as “millipoints.” However, even within the community that supports this approach there are two schools of thought. Some believe that there should be a standard weighting, while others feel that companies should be free to weight impacts as they see fit. One of the advantages of a standard weighting, as is used in the Okala approach among others, is that products can be compared to each other more easily since the single impact scores are only meaningful if compared among products with the same weighting. A second benefit is that companies can’t “game” the

<sup>42</sup> Source: T.G. Gloria, B.C. Lippiatt, and J. Cooper, “Life Cycle Impact Assessment Weights to Support Environmentally Preferable Purchasing in the United States,” *Environmental Science and Technology*, November/December 2007.

assessment to make their products look better than they are by emphasizing the areas in which the product does well and decreasing the effect of categories in which the product has problems.

The advantage of variable weighting approaches is that they can be customized to fit an organizations goals and values. For instance, if an organization is making global warming a priority, it may want to weight that category much more heavily as it is assessing the impacts of its products. As long as the weighting remains constant within its own LCAs, the disproportionate weight it gives to this category is fine. There are some sustainability accounting and reporting standards that focus almost exclusively on greenhouse gas emissions, making it useful for organizations using them to put almost all of the weight on that subset of impact factors.<sup>43</sup>

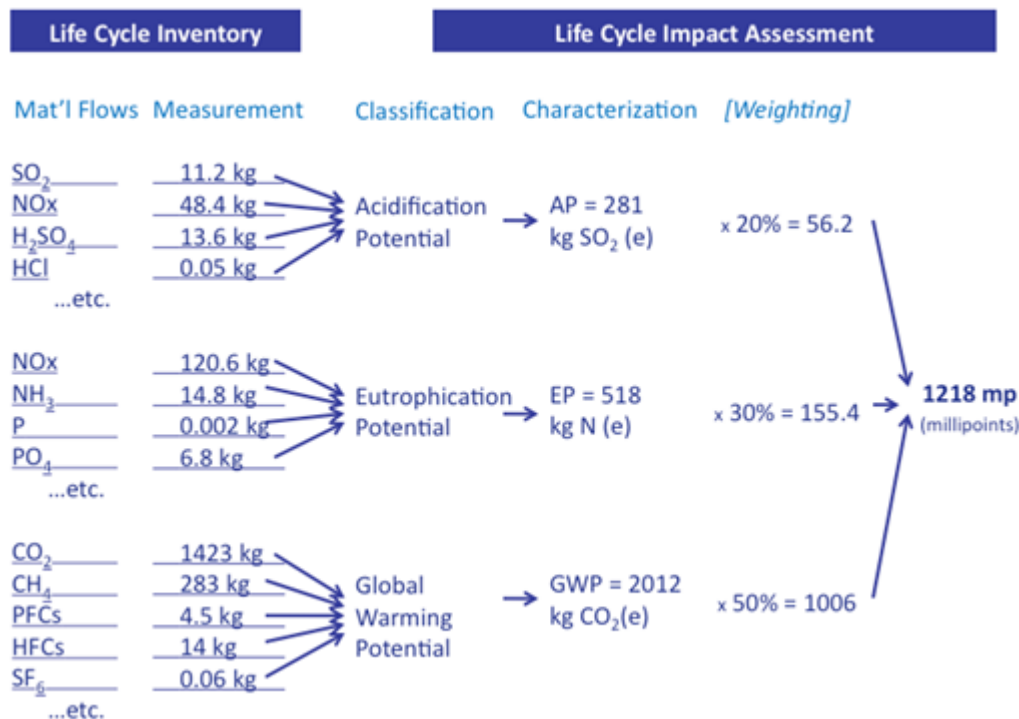

### Interpretation

Although listed fourth, life cycle interpretation actually occurs throughout the whole LCA. It involves the ongoing process of clarifying, quantifying, checking, and evaluating the information used by, and resulting from, the life cycle inventory (LCI) and impact assessment (LCIA) phases. The standard covering LCAs, ISO 14044, gives two main objectives:

- Analyze results, reach conclusions, explain limitations, and provide recommendations based on the findings of the preceding phases of the LCA, and to report the results of the life cycle interpretation in a transparent manner.
- Provide a readily understandable, complete, and consistent presentation of the results of an LCA study, in accordance with the goal and scope of the study.

<sup>43</sup> Carbon footprint standards such as PAS 2050 and the GHG Protocol fit this description.



To achieve these objectives, the ISO standard states that interpretation should cover at least three major elements.

- Identification of the significant issues based on the LCI and LCIA. Which life cycle phases or components stand out as major contributors to overall impact? What are the anomalies?
- Evaluation which considers completeness, sensitivity, and consistency checks. Is all the information needed for interpretation present in the LCI and LCIA? How reliable is the information related to any identified significant issues? How much do changes in such factors influence the overall results? Are all of the assumptions, data, characterization factors, etc. that were used in the assessment consistent internally and with the overall goal and scope of the LCA?
- Conclusions, recommendations, and reporting. As discussed in later sections of this guide, a great deal of an LCA's value depends on how its results are communicated to people involved in making relevant decisions, whether other designers, engineers, management, marketers, or other parts of the supply chain.

It is very important to note that no matter how carefully assembled, analyzed, assessed, and measured, LCAs are never the "real" answer. They require interpretation, which in turn requires transparency and judgment. The data sources, assumptions, and all other relevant information needs to be transparent to decision makers so that they can understand the full context of the results of the life cycle inventory assessment. Deciding among design options is not as easy as just comparing LCIA numbers, whether single- or multi-factor, weighted or not. LCIA results can be a source of insights, but do not stand alone in guiding product development choices. Engineers will need to take them in the context of the other attributes they are trying to optimize, including cost, manufacturability, performance, and so on. In addition, there are myriad other factors guiding product development decisions not covered by LCAs, including social impacts and acceptance, pricing, political agendas, and regulations.

## Appendix C - LCA Tools and Methods

### Commonly used LCA Tools

A 2006 survey of 65 LCA practitioners<sup>44</sup> reported that:

58%\* used GaBi (Sphera)

31%\* used SimaPro (PRé Consultants)

11%\* used TEAM (Ecobilan)

Other tools cited:

- BEES (NIST)
- Umberto (ifu Hamburg)
- ECO-IT (PRé Consultants)
- Excel-based spreadsheets

---

<sup>44</sup> Cooper, J.S.; Fava, J. (2006), "Life Cycle Assessment Practitioner Survey: Summary of Results", Journal of Industrial Ecology

\* percentages include overlap due to usage of multiple tools

- Math package (e.g. MATLAB, Mathematica)

### Impact Assessment Methodologies

Impact assessment methodologies are the systematic calculations that are used to get from an LCI (life cycle inventory) flow, such as carbon dioxide or sulfur dioxide, to the environmental impact that it causes. The results of these calculations typically measure either midpoint or endpoint effects (endpoint effects are sometimes called damage effects). For example, the following chart shows how some midpoint effects map to their respective endpoint effects<sup>45</sup>:

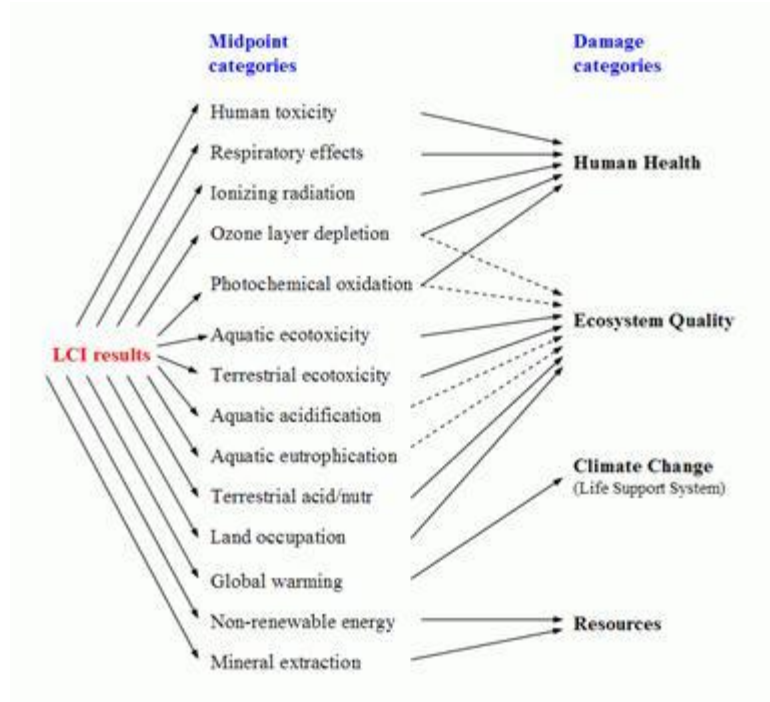

While the endpoint or damage effects are the ones we really care about, these can be difficult to measure directly. For example, how many degrees of global average temperature increase are caused by one firm's activities? It's very hard to measure such a fractional effect, so we tend to measure the midpoint effect of greenhouse gas emissions, which lead to global average temperature increases. Most impact assessment methodologies use midpoint measurements.

There are several impact assessment methodologies that are commonly used in the LCIA steps of an LCA, which include classification and characterization, and optionally normalization and/or weighting. Some of these impact assessment methodologies are described below.<sup>46</sup>

### CML ("CML 1996", "CML 2001")

The CML methodology, developed by the Institute of Environmental Sciences at the University of Leiden in the Netherlands, is the most widely-used and often considered the most complete methodology. It uses primarily European data to derive its impact factors. It groups the LCI results into midpoint

<sup>45</sup> Adapted from "IMPACT 2002+" LCIA methodology / Dr. Olivier Jolliet, Univ. of Michigan

<sup>46</sup> <http://www.gabi-software.com/support/gabi/gabi-5-lcia-documentation/life-cycle-impact-assessment-lcia-methods/>

categories, according to themes; these themes are common mechanisms (e.g. climate change) or groupings (e.g. ecotoxicity). There is a “CML 1996” and a “CML 2001” method. Its results can be viewed as a spreadsheet that presents characterization factors for more than 1700 flows (2001).

The CML impact assessment methodology is the one we have chosen to calculate the results for SOLIDWORKS Sustainability.

For more information, see <https://www.universiteitleiden.nl/en/research/research-output/science/cml-ia-characterisation-factors>

### **Eco-Indicator (“95”, “99”)**

Like the CML methodology, the Eco-Indicator method includes classification (“categories of effect”) and characterization steps, grouping the LCI results into midpoint categories.

These impact data are then weighted according to a social evaluation process. For example, the Eco-Indicator 95 method specifies that 1 death per 1,000,000 inhabitants is equal to 5% surface loss of an intact ecosystem. This weighting is performed in order to compare different types of environmental effects directly together; the results can then be presented as a single score, the so-called Eco-Indicator score.

Impact factors for Eco-Indicator 99 are collected and published in a spreadsheet by the Institute of Environmental Sciences, Leiden University, The Netherlands, and are furnished by PRÉ Consultants, makers of the Sima Pro LCA software package.

The data are then normalized, or divided by a common reference value, to facilitate communication. In the case of Eco-Indicator 95, the data are normalized after classification using the annual European contributions per inhabitant for the impact category. In Eco-Indicator 99, the data are normalized based on published information furnished by PRÉ Consultants<sup>47</sup>.

Because Eco-Indicator is a single-score LCA methodology, we do not include it as an option in SOLIDWORKS Sustainability.

### **TRACI**

The “Tool for the Reduction and Assessment of Chemical and Other Environmental Impacts”, or TRACI, is an impact assessment methodology developed by the US Environmental Protection Agency. As with the other impact assessment methodologies, TRACI is primarily a midpoint approach. It differs from the CML methodology in that the data comes primarily from North American sources. However, the TRACI methodology is not as comprehensive or complete as the CML method. For this reason, we have programmed SOLIDWORKS Sustainability to perform the calculations using TRACI as well as CML, but haven’t enabled the TRACI results as an option.

The following is a handy chart that demonstrates the difference between single-score and multiple-indicator impact assessment methodologies.

---

<sup>47</sup> <https://pre-sustainability.com/articles/eco-indicator-99-manuals/>

Life Cycle Inventory

Life Cycle Impact Assessment

